

WELCOME and THANK YOU for your interest in Valley Custom Door. Since 1960, we have been manufacturing quality cabinet doors and a wide variety of products for cabinet and re-facing shops across the country. We pride ourselves on combining good old fashion personal service with high-tech manufacturing capability. With Valley Custom Door as your supplier, you can be assured that whether your order is for 1 door or 1000 doors, our commitment to quality and customer satisfaction is always the priority.

All products can be ordered unfinished or pre-finished in one of our many standard finishes or custom stain matched.

We believe our commitment to quality, service and on-time deliveries is unsurpassed... we think you will too!

	Page Number		Page Number
Pricing	3	Routed Finger Pulls	41
New Customers	3	Radius Corners	41
Payment Terms / Terms	3	Half Lap Edge	41
Shipping	3	Veneered Bread Board	41
Freight Damage	3	Wine Rack Lattice	41
Warranty & Remake Policy	3	Butt Doors	42
Rush Orders	3	Lazy Susan or Corner Doors	42
Price Quotations	3	Lazy Susan Trays	42
Ordering	4	Waste Container Pull-Outs	42
Steps To Follow When Ordering Doors & Drawer Fronts	4	Valances, Shelves, Profiles, Pricing	43
Wood Species Guide	5	Appliance Panels	44
Standard Grade	5	Options - Hinge Boring	45
Premium Grade	5	Options - Concealed Hinge Boring Chart	46
Rustic Grade	5	Custom Wood Hoods	47-48
Paint Grade	5	Wood Hood Liners & Blower Units	49
Value Grade	5	Appliance Garages	50
Product Samples	6	Mantle Shelf	51
Door Construction	7	Notes Page	52
Raised Panel Profiles	8	Face Frame Stock – Plain	53
1/4 Flat Veneer MDF Core Panels	8	Face Frame Stock – Beaded	54
V-Groove Cost Per Square Foot	8	Millwork	55-58
Stile & Rail Profiles	9	Millwork Pricing	59-60
5-Piece Drawer Front Outside Edge Profiles	10	3/4 S4S Face Frame Stock	61
3/4" Slab Style Drawer Fronts	11-12	1/4 S4S Face Frame Stock	62
5-Piece Drawer Fronts	13	Veneer & Plywood Panel Pricing	63
Raised Panel Doors	14	Mantels & Surrounds	64-80
Raised Panel Doors/Pricing	15	Mantels & Surrounds Ordering Information	65
Louvered Door/ Pricing	16	Mantels & Surrounds Warranty Policy	65
1/4 Panel Doors	17-18	Mantels & Surrounds Lead Times	65
Framed Glass Doors	19	Mantels & Surrounds Packaging & Shipping	65
Framed Glass Doors w/Mullions/Pricing	20	Mantels & Surrounds Pricing	65
Mitred Door & Drawer Fronts	21-23	Mantels & Surrounds Prefinishing	66
Mitred Door & Drawer Fronts Pricing	24	Mantels & Surrounds Order Forms	67-80
Applied Molding Doors And Drawer Fronts	25-26	Devonshire	67-68
Applied Molding Doors And Drawer Fronts Pricing	27	Bradbury	69-70
Notes Page	28	Fairmont	71-72
Quarter Circle Doors	29	Glenbrook	73-74
Solid Wood Doors	30	Edgewood	75-76
MDF Veneer Doors	31	Chesapeake	77-78
Wainscot Panels	32	Ashby	79-80
One-Piece MDF Glass And Mullion Doors	33	Index	81
One-Piece MDF Raised Panel Doors	34		
Prefinishing	35-36		
Dovetail Drawer Options	37-39		

3 HOW TO USE A VALLEY CUSTOM DOOR SPECIFICATION GUIDE

PRICING

All prices shown are LIST, please contact the customer service department to determine what discounts may apply.

All door and drawer front pricing is to be figured based on the square footage of each item. To determine the square footage, you must first round up the width and height size to the next whole inch, then multiply them together and divide by 144. There is a minimum charge of 1 square foot on doors and ½ square foot on drawer fronts.

All other products have price tables and instructions located in each product section.

Pricing is subject to change without notice.

NEW CUSTOMERS

All new customers will be set up as 50% down payment/C.O.D. Cash accounts until the Customer Information Form is filled out and returned for evaluation by our credit department. Until other payment terms have been established, all orders will require that a 50% down payment be received before they are scheduled for production.

PAYMENT TERMS

Based on the information supplied on the Customer Information Form, payment terms will be assigned by our credit department. If the Customer Information Form is not filled out, payment terms will automatically be 50% down payment/C.O.D. Cash, (all payments must be a cashier's check or money order.)

- Net/30 Days – Full balance is due 30 days from the **date of the invoice** (not to be confused with the monthly statement date). Credit limits will be set for all open accounts.
- C.O.D. Regular – A company or personal check will be accepted for payment upon delivery.
- C.O.D. Cash – A cashier's check or money order is required for payment upon delivery.
- 50% D.P. / C.O.D. Cash – A 50% down payment on each order by cashier's check or money order, balance paid by cashier's check or money order on delivery.
- VISA, MasterCard or American Express are accepted as alternative methods of payment to the terms listed above.

SHIPPING

All orders are packaged extremely well using heavy corrugated boxes and expandable bagged packing foam to protect our products while in transit. UPS is our primary shipper, but in some cases a common carrier is required. There is **no additional charge for packaging** your orders, but the actual shipping charges are not included in the cost of our products. A minimum of \$XX.XX will be charged to cover the cost of the skid for common carrier shipments.

FREIGHT DAMAGE

You must report freight damage immediately to your customer service representative. Products that have been damaged while in transit will be remade on a priority schedule and shipped out as soon as possible. We will process the freight claim with the carrier, but **you must save the damaged products and the packaging it came in** for the carrier to inspect if they choose. **If the delivery was made by a common carrier, you must make a notation on the bill of lading of any visible damage to the outside of the skid or packaging. If the delivery was made by UPS, you must save the damaged products and all of the packaging in order for us to file a claim. We reserve the right to have defective products returned for our inspection, and upon inspection, we will determine if charges will apply for the products remade.**

WARRANTY AND REMAKE POLICY

All of our products are guaranteed to be free from defect in material and workmanship for one year from the date of shipment. Warp tolerance on doors will be ⅛" from diagonal corners; size tolerance on doors and drawer boxes will be +/- 1/32". Valley Custom Door will expedite the production of replacements or repair of defective products as they were originally ordered and ship as soon as possible. Valley Custom Door will not be liable for additional costs incurred by the customer for finishing, installation, or labor to remove or install new product. We reserve the right to have defective products returned for inspection.

RUSH ORDERS

Orders requesting expedited service will be accepted based on our workload at the time. Please call your customer service representative for more information on availability and price.

PRICE QUOTATIONS

Depending on workload, requests for price quotes on standard items are usually returned the same day they are received. To help us give you an accurate quote, please provide as much information as possible, such as wood species, door styles, profiles, quantity, sizes and drawings for special custom items.

ORDERING

We accept orders in any of the following ways:

- Fax – 1-920-336-5956 (24 hours a day, 7 days a week)
- Email – contact customer service for order forms that can be emailed
- Phone – 1-800-236-8981 (Monday – Friday from 6:30 am to 4:30 pm CST) Orders taken over the phone will be **read back** for customer approval. Any corrections not made during the **read back** become the customer’s responsibility.

We manufacture the actual size listed on the order and do not work from opening sizes.

After an order is entered into our system, a Price Quotation will be faxed to you for confirmation of price, quantity and all order specifications. The Price Quotation must be signed and returned confirming that the order is correct as printed before the order can be scheduled for production. Any changes made BEFORE the order is signed off on will be made without penalty; changes made to an order AFTER it has been signed off on but is not yet in production, will incur additional charges. Changes to an order already in production will not be accepted. Call your customer service representative to check whether changes to your order can be made.

A confirming Order Acknowledgement with an estimated ship date will be faxed or emailed to you for your records.

STEPS TO FOLLOW WHEN ORDERING DOORS AND DRAWER FRONTS

1. Doors and drawer fronts must be ordered by actual door size needed, not the opening size. All sizes need to be ordered in increments of 1/16".
2. Please check minimum sizes listed below each sketch for the doors and drawer fronts that you ordered.
3. If you are using concealed hinges, please check page 42 to see if the edge you have chosen is compatible with cup hinges. All arched doors must have hinge side noted.
4. Outside edge profiles E-103 and E-107 are a 3/8" lip style. Please specify if the pairs of doors are to be edged on three sides only by indicating "Butt Door" next to the door size. If the doors are arched, please specify the butt edge by indicating "Butt Left" or "Butt Right".
5. All doors 48" + in height will automatically have a center rail added unless otherwise specified on the order form, or a center rail isn't available for that door style. Doors made without a center rail will not be guaranteed against warping.
6. All doors 24" + in width will not automatically have a center stile added. These doors will not be guaranteed against warping.

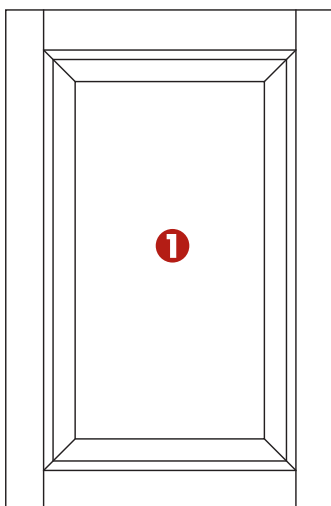

- 1 Design Sketch
- 2 Style Number
- 3 Price Group Number
- 4 Minimum Sizes, Width x Height

- 2 301
- 3 Price Group 100
- 4 7¼ x 7¼

INCLUDED IN THE PRICE PER SQUARE FOOT

- Outside edge profiles
- Panel profiles
- Stile and rail profiles
- Finish sanding
- Packaging for UPS shipments

*Freight charge is not included

5 HOW TO USE A VALLEY CUSTOM DOOR SPECIFICATION GUIDE

WOOD SPECIFICATIONS GUIDE					
WOOD SPECIES	Standard	Premium	Rustic	Paint Grade	Value Grade
Alder*	X	X	X		
Ash White	X	X			
Beech-European	X	X			
Birch Red	X	X			
Birch White	X	X		X	X
Butternut	X	X			
Cedar Knotty	X				
Cherry*	X	X	X		X
Hickory*	X	X	X		
Llytus	X	X			
Mahogany Genuine	X	X			
Mahogany African	X	X			
Maple Hard White*	X	X	X		X
Maple Hard White Birdseye	X	X			
Maple Soft	X	X			
Oak Quarter Sawn Red	X	X			
Oak Quarter Sawn White	X	X			
Oak Red*	X	X	X		X
Oak Rift Red	X	X			
Oak Rift White	X	X			
Oak White	X	X			
Pine White Clear	X	X			
Pine White Knotty*	X				
Poplar	X	X			
Walnut	X	X			

STANDARD GRADE

All of our standard grade wood is uniform in color (with the exception of Hickory) and is well suited for most light to medium-dark stain applications. Each door will be selected for uniform color and graining.

Each type of wood has its own unique characteristics some of which will be allowed, for example:

Hard Maple is a clear, white wood but it may have a few small pin knots and occasional mineral streaks seen in the machined areas of the doors. Occasional patterns of "birds eye" and "worm tracks", which are characteristic of maple, may be visible.

Cherry is a colorful wood that may have a few small pin knots and an occasional streak of sapwood in the machined areas with small gum spots and mineral flecks visible.

Red Oak may have small pin knots and occasional mineral streaks visible.

Hickory typically will have dramatic color swings from nearly white to brown and may have any combination of color seen in each door with small pin knots and mineral streaks common.

PREMIUM GRADE

Each piece will be hand-selected to ensure a superior color and grain match on the face of the doors. Very few of the natural wood characteristics allowed in the standard grade will be present on the face of the doors. Premium Grade is recommended when using a natural or very light sprayed on stain.

Premium Grade: add 20% to the List Price.

*Available in 5/4 Stock, Add 25% to List Price

RUSTIC GRADE

Only solid wood doors and drawer fronts can be made using Rustic Grade. Each Rustic Grade will have many variations allowed such as mineral streaks, sap and heartwood. Knots are common but will be structurally sound and may have slight voids or cracks around them.

Rustic Alder will have larger cracks and knot holes allowed but they will not be greater than 1/4" in diameter.

PAINT GRADE

May have extreme color and grain variations along with mineral streaking and heartwood allowed. Because solid wood will expand and contract, we recommend that an MDF panel is used for painted finishes rather than solid wood. When an order is placed for UNFINISHED Paint Grade doors, we will use solid wood panels unless you specify MDF panels. **If we are painting the order, we will automatically substitute an MDF panel whenever possible, unless you specify a solid wood panel be used.**

VALUE GRADE

Developed for price sensitive projects and is best suited for use with Medium to Dark finishes. Value Grade will have a mixture of sap and light heartwood blended throughout as well as natural mineral streaks may be present on the face and profiled areas.

NOTE: The 1/4" Veneer panels used in our flat panel doors will generally stain darker than the solid wood frames. If a stain match is required, we recommend that a solid wood reverse panel (P-204) is used instead of the 1/4" veneer panel.

PRODUCT SAMPLES

One sample door of your choice will be furnished free of charge. Any additional samples ordered will be chargeable but will have a sample discount applied. Contact our customer service department for more information on sample discounts and a list of stock sample doors available.

A. Color Sample Display Board makes it easy for your customers to pick the finish color that is just right for their project.

Size 35 1/2" W x 53" H. Each board will hold a maximum of forty-nine color chips. **List Price \$XXX.XX**



B. Compact Door Display is the perfect solution for customers with limited showroom area.

24" W x 22 1/2" H will display up to eleven 12" x 15" sample doors. Contact customer service for a list of stock doors from which to choose. Price includes 11 stock sample doors. Custom made doors will have an upcharge and longer lead time. **List Price \$XXX.XX**

C. The Sales Kit will keep your sales presentations organized and looking good with the high quality rolling case w/telescopic handle. Each case comes complete with:

- 5 12" x 15" Prefinished Stock Sample Doors – Contact customer service for a list of stock doors to choose from. Custom made doors will have an upcharge and longer lead time.
- 1 Panel Profile and Mitred Rail Board
- 1 Color Chain of Oak, Cherry, Hard Maple and Glazed Samples
- 1 Refacing Product Sample Chain with Veneer and Solid Wood Samples
- Full-color Product Brochures
- Pricing & Specification Guide

Sales Kit List Price \$XXX.XX Case Only List Price \$XXX.XX

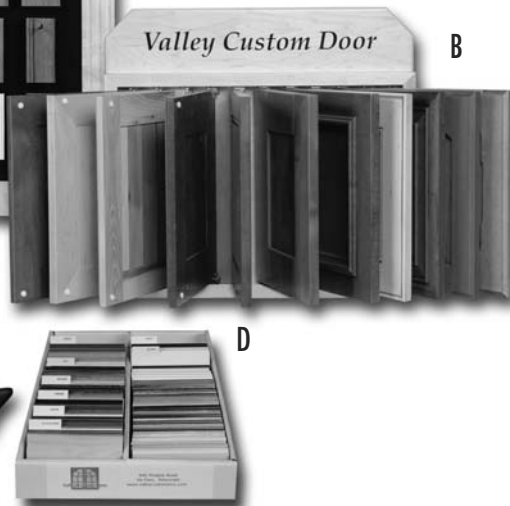

D. Complete Set of Color Samples All standard finishes organized by wood species and colors available. Great for showroom displays or sales people on the go. **List Price \$XXX.XX**



E. Display Cabinet with doors, color samples, moulding samples and dovetailed drawer boxes. Overall size is 48" wide x 20" deep x 98" high and includes the following display products:

- 21 Prefinished Stock Sample Doors size 12" x 15" – Contact customer service for a list of stock doors to choose from. Custom made doors will have an upcharge and longer lead time.
- 32 Prefinished Standard Moulding Samples
- 49 Color Sample Chips Showing Standard Stain and Glaze Finishes
 - 1 Standard 5/8" Solid Maple Dovetail
 - 1 Standard 5/8" Solid Maple Dovetail with Scoop Front
 - 1 Standard 5/8" Solid Maple Dovetail with 7/16" Tab Front
 - 1 Standard 5/8" Solid Maple Dovetail Rollout Shelf

All drawer tracks used are the Blum Tandem Full-extension. **List Price: \$X,XXX.XX**

7 DOOR CONSTRUCTION

The stiles and rails of our doors are constructed by using a mortise and tenon joint. The tenon is $\frac{5}{8}$ " long to give you the strongest door available. *Our standard stile and rail width on Cope and Stick style doors is $2\frac{1}{4}$ " with the exception of style 324 and 424 which have 3" stiles and rails. Our standard center rail width is $2\frac{1}{2}$ ". The finish thickness of the doors is $\frac{3}{4}$ ". All raised panel inserts are $\frac{5}{8}$ " thick and are made out of solid wood. Flat panels are $\frac{1}{4}$ " thick and are an MDF Core Veneer material.

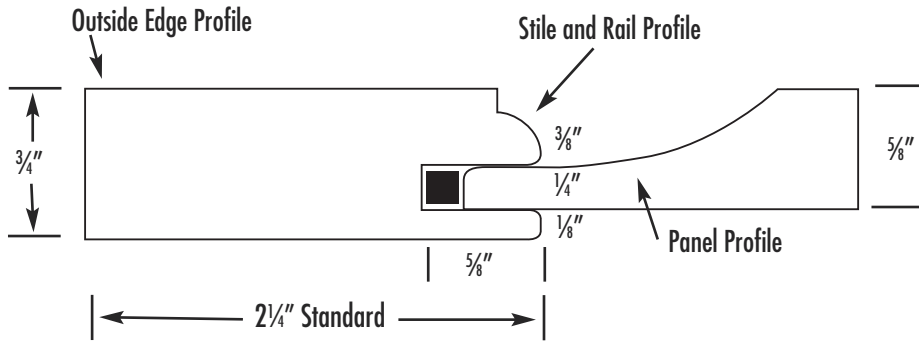

* Wider and narrower frames are available on Cope & Stick door styles and on Mitred Door Style #316. (See pricing below)

TYPICAL SLAB DRAWER FRONT

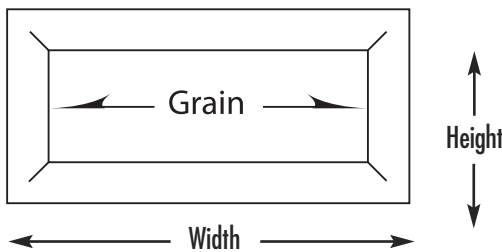

TYPICAL 5-PIECE COPE & STICK DRAWER FRONT

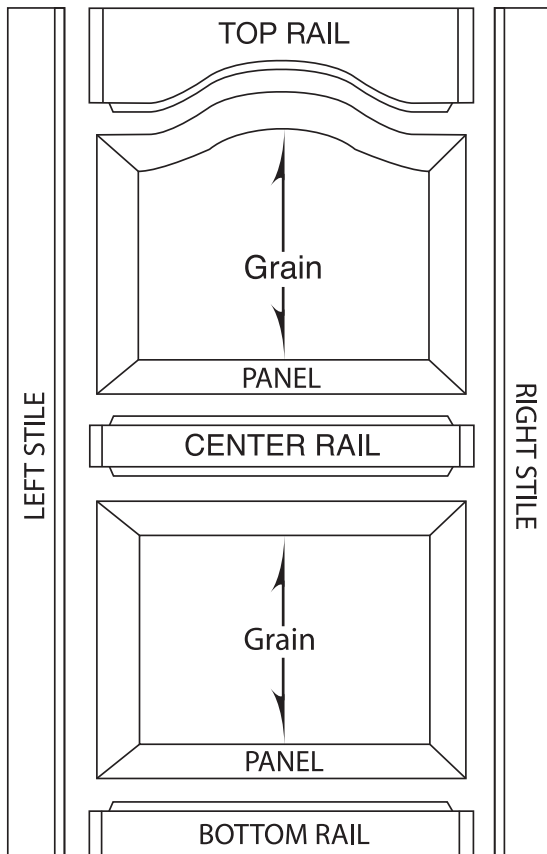
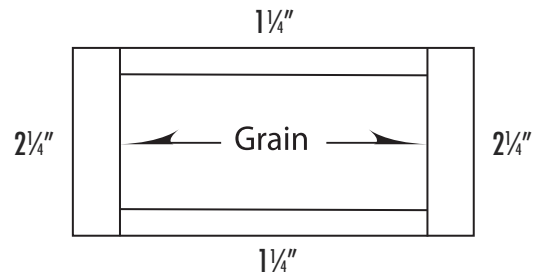

If ALL Stiles & Rails on the door are the same size but are NOT our standard 2-1/4" width:

	Amount to Add per SQUARE FOOT
1-3/4" to 2-3/16"	SX.XX
2-5/16" to 3"	SX.XX
3-1/16" to 3-1/2"	SX.XX
3-9/16" to 4"	SX.XX
Over 4"	call for pricing

All Stiles and Rails on the door are NOT the same size:

(Applies to Cope & Stick Style Doors ONLY.)	Amount to Add per Stile & Rail
1-3/4" to 2-3/16"	SX.XX
2-5/16" to 3"	SX.XX
3-1/16" to 3-1/2"	SX.XX
3-9/16" to 4"	SX.XX
4-1/16" to 4-1/2"	SX.XX

TYPICAL MITRED CONSTRUCTION



MITRED JOINT:
All of our mitred doors are constructed using a blind mortise and tenon joint.

RAISED PANEL PROFILES * Indicates speed profile.

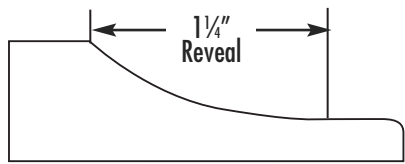

*P-201

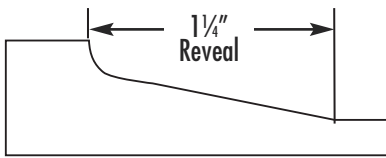

*P-202

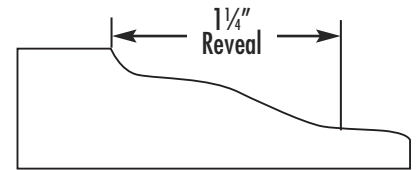

P-203

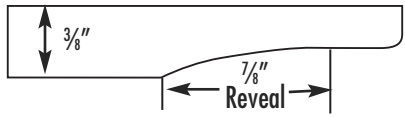

*P-204

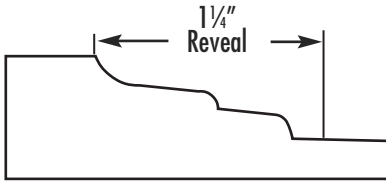

P-207

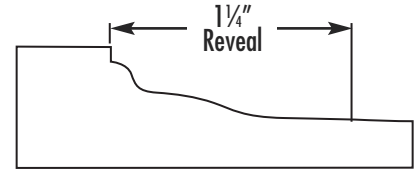

*P-209

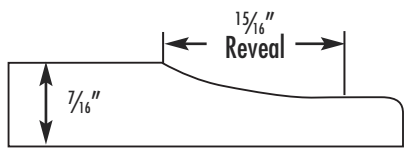

*P-210

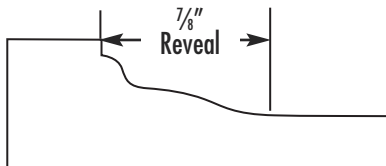

P-211

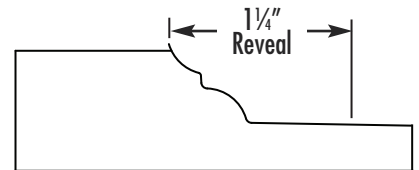

P-217

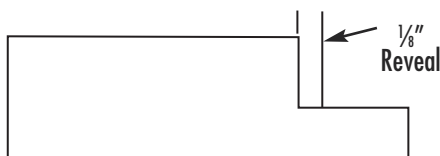

P-208

Available in MR-367 and drawer front DF-367 ONLY

1/4" FLAT VENEER MDF CORE PANELS All 1/4" Panels qualify as a Speed Profile when used with a qualifying outside edge.

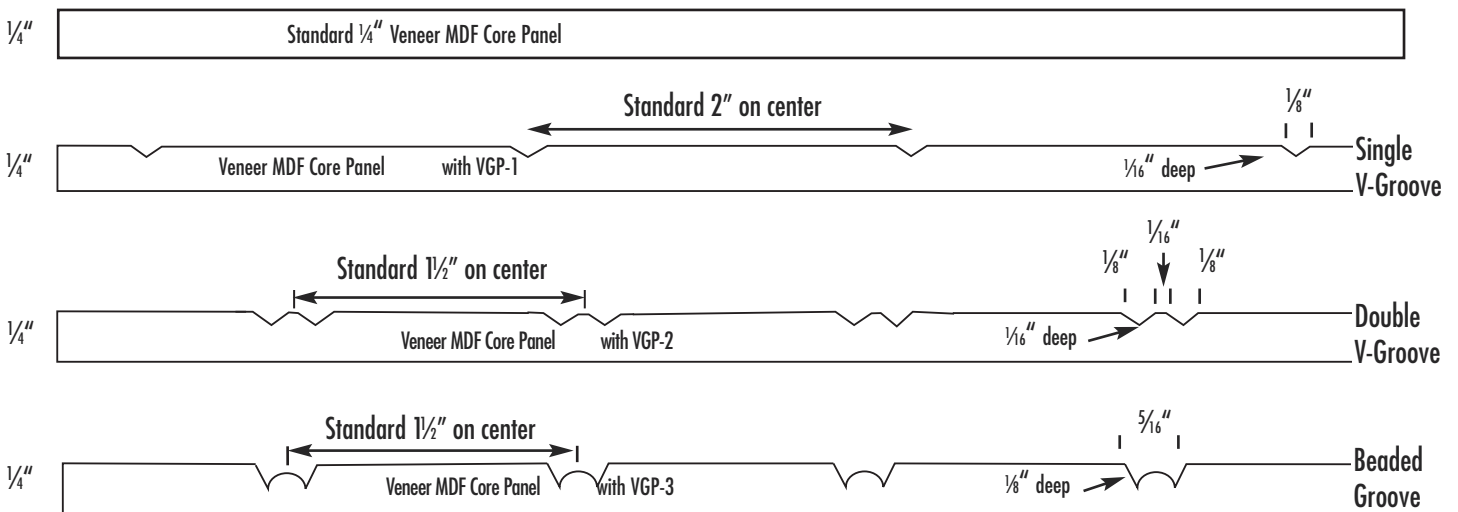

NOTE: The VGP-1 and VGP-2 will have the raw core exposed in grooves. On the VGP-3, the actual bead is raw core. The raw core area is going to stain darker than the veneered surface. For a uniform stain color we recommend ordering the door as a Raised Panel style with a P-204 Panel and indicate which groove should be added. This will ensure that your door will have a uniform finish color.

V-GROOVE COST PER SQUARE FOOT Note: One square foot minimum charge will apply.

Spacing	1/2"	1"	1-1/2"	2"	2-1/2"
Cost Per Square Foot	X	X	X	X	X

9 STILE & RAIL PROFILES

STILE & RAIL PROFILES

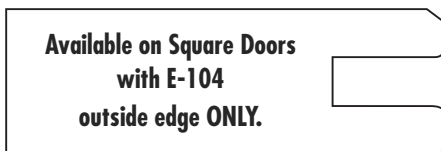
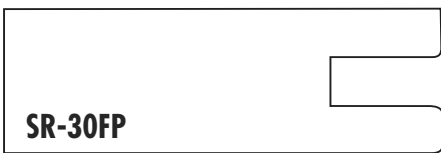
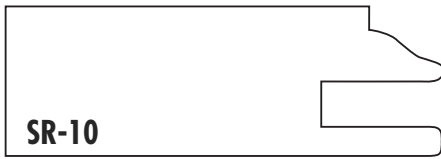

***SR-40**
(This profile runs the full length of the stiles)

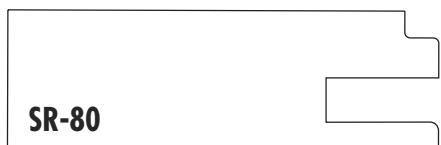
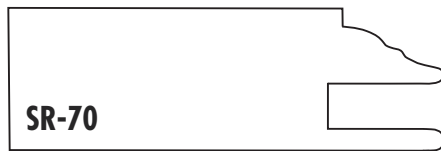

STILE & RAIL PROFILES/FOR GLASS DOOR ROUTED FOR VINYL RETAINER

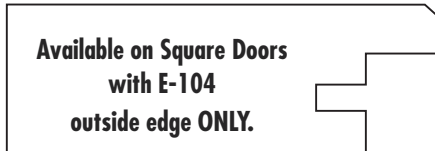
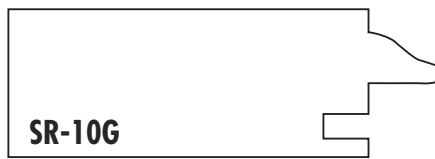

***SR-40G**
(This profile runs the full length of the stiles)

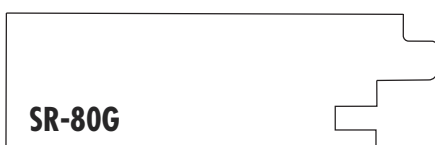
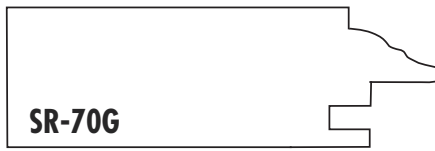

**No G profile available for SR-86
must be Squared Out of Glass.**

MULLION PROFILES

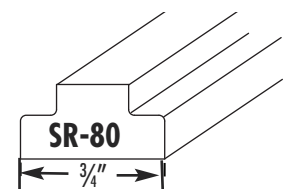
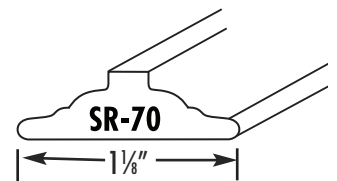
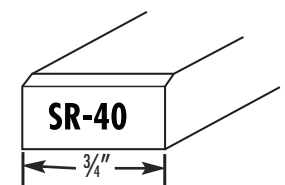
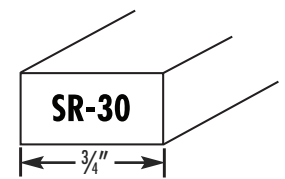
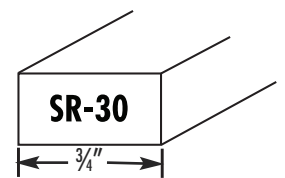
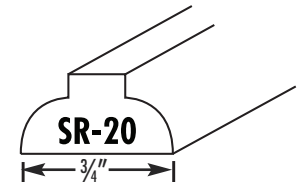
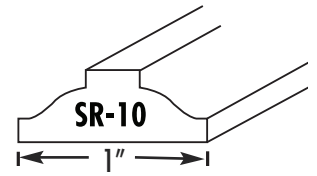

NA

These outside edge profiles are available on all Raised and Flat Panel doors and 5-Piece Drawer Fronts.

***Indicates speed profile**



***E-101**

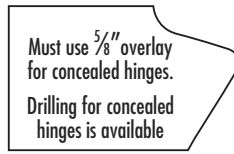

***E-102**

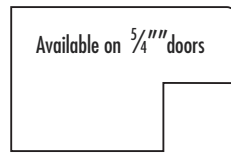

E-103

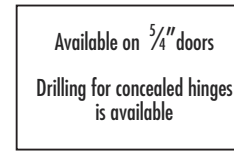

***E-104**

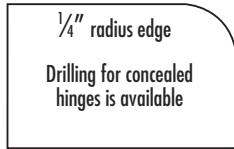

***E-105**

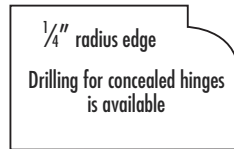

***E-106**

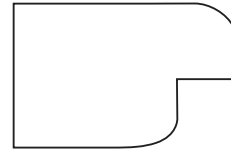

E-107



***E-108**

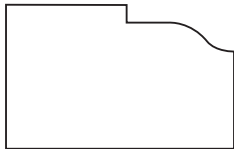

E-109

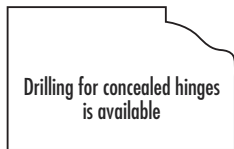

***E-110**

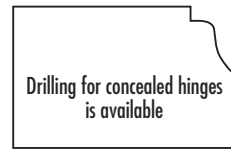

E-111



E-112

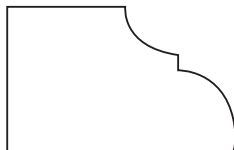

E-113

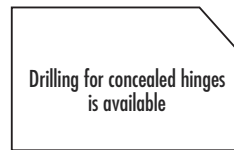

E-114

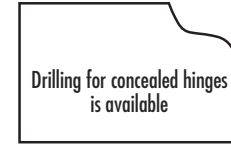

E-115



***E-116**

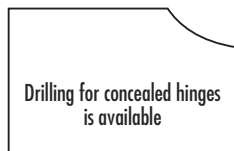

***E-117**

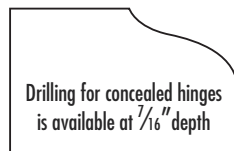

***E-118**

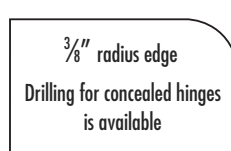

E-121



E-122

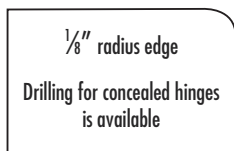

E-123

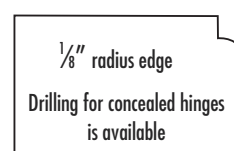

E-124

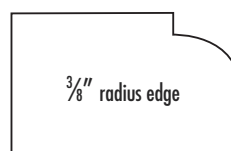

E-126



***E-127**

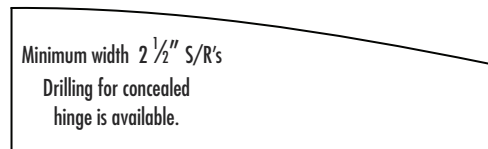

E-129



E-130

Please reference page 46 for detailed concealed hinging information.

11 3/4" SLAB STYLE DRAWER FRONTS

SLAB STYLE DRAWER FRONTS

NOTE: All drawer fronts will have a 1/2 square foot minimum charge.

Solid wood drawer fronts are available with any routed outside edge profile shown below. Drawer fronts with a minimum height requirement are listed on the sketch.

WOOD SPECIES Slab	E-Edge	E-122
Alder*	X	X
Alder Rustic	X	X
Ash White	X	X
Beech	X	X
Birch Red	X	X
Birch Value	X	X
Birch White	X	X
Butternut	X	X
Cedar Knotty	X	X
Cherry*	X	X
Cherry Rustic	X	X
Cherry Value	X	X
Hickory*	X	X
Hickory Rustic	X	X
Lyptus	X	X
Mahogany Genuine	X	X
Mahogany African	X	X
Maple White Rustic	X	X
Maple Hard White Value	X	X
Maple Hard White*	X	X
Maple Hard White Birdseye	X	X
Maple Soft	X	X
Oak Red Quarter Sawn	X	X
Oak White Quarter Sawn	X	X
Oak Red*	X	X
Oak Red Rift	X	X
Oak Red Rustic	X	X
Oak Red Value	X	X
Oak White Rift	X	X
Oak White	X	X
Paint Grade*	X	X
Pine White Clear	X	X
Pine White Knotty*	X	X
Poplar	X	X
Walnut	X	X

*Available in 5/4 stock add 25%.

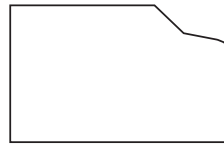

E-101



E-102



E-103



E-104

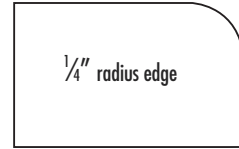

E-105

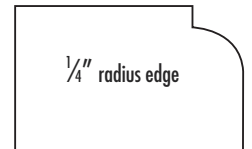

E-106

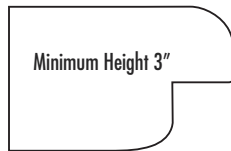

E-107

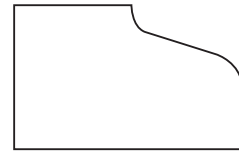

E-108



E-109

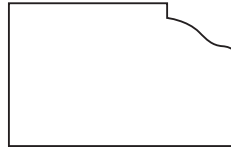

E-110



E-111



E-112



E-113

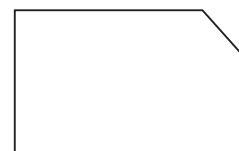

E-114

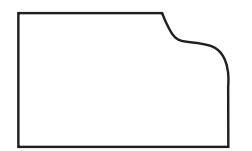

E-115

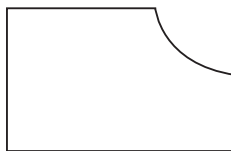

E-116



E-117

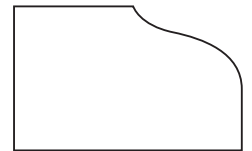

E-118

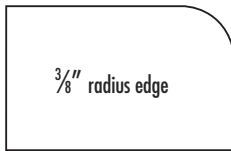

E-121

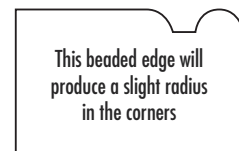

E-122

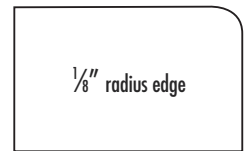

E-123

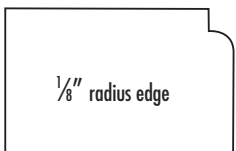

E-124

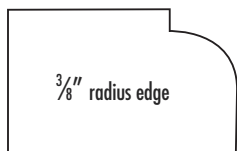

E-126

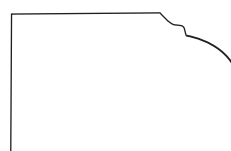

E-127



E-129



E-130

SLAB STYLE DRAWER FRONTS *All drawer fronts will have a 1/2 square foot minimum charge*

These outside edge profiles are used to make a slab drawer front look like a raised panel style without a frame. Minimum height requirements listed on each sketch.

WOOD SPECIES	Slab DF-Edge	900 Series
Alder*	X	X
Alder Rustic	X	X
Ash White	X	NA
Beech European	X	NA
Birch Red	X	NA
Birch Value	X	NA
Birch White	X	NA
Butternut	X	NA
Cedar Knotty	X	NA
Cherry*	X	X
Cherry Rustic	X	X
Cherry Value	X	NA
Hickory*	X	X
Hickory Rustic	X	X
Lyptus	X	NA
Mahogany Genuine	X	NA
Mahogany African	X	NA
Maple White Rustic	X	NA
Maple Hard White*	X	X
Maple Hard White Birdseye	X	NA
Maple Hard White Value	X	NA
Maple Soft	X	X
Oak Red Quarter Sawn	X	NA
Oak White Quarter Sawn	X	NA
Oak Red*	X	X
Oak Red Rift	X	NA
Oak Red Rustic	X	NA
Oak Red Value	X	NA
Oak White Rift	X	NA
Oak White	X	NA
Paint Grade*	X	X
Pine White Clear	X	NA
Pine White Knotty*	X	X
Poplar	X	NA
Walnut	X	NA

*Available in 5/4 stock add 25%.

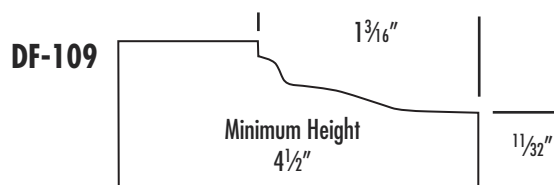
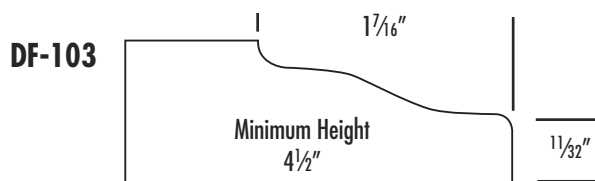
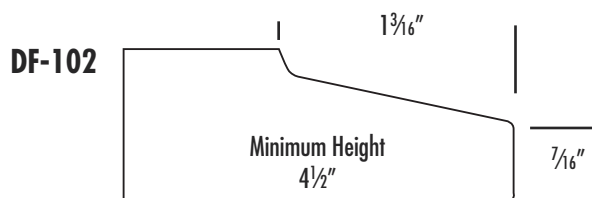
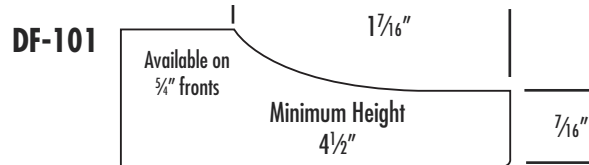

1" SLAB STYLE DRAWER FRONTS

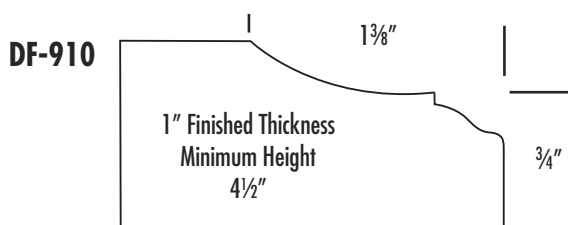

The DF-906 and DF-910 are available using 5/4 stock only. (900 Series price group includes cost for 5/4 material.)

13 5-PIECE DRAWER FRONTS

5-PIECE DRAWER FRONTS

NOTE: All drawer fronts will have a 1/2 square foot minimum charge.

WOOD SPECIES	DF-301	DF-324	DF-401	DF-424
Alder*	X	X	X	X
Alder Rustic	X	X	NA	NA
Ash White	X	X	X	X
Beech	X	X	NA	NA
Birch Red	X	X	NA	NA
Birch Value	X	X	X	X
Birch White	X	X	X	X
Butternut	X	X	NA	NA
Cedar Knotty	X	X	NA	NA
Cherry*	X	X	X	X
Cherry Rustic	X	X	NA	NA
Cherry Value	X	X	X	X
Hickory*	X	X	X	X
Hickory Rustic	X	X	NA	NA
Lyptus	X	X	X	X
Mahogany African	X	X	NA	NA
Mahogany Genuine	X	X	NA	NA
Maple White Rustic	X	X	NA	NA
Maple Hard White*	X	X	X	X
Maple Hard Value	X	X	X	X
Maple Hard White Birdseye	X	X	NA	NA
Maple Soft	X	X	X	X
Oak Red Quarter Sawn	X	X	X	X
Oak White Quarter Sawn	X	X	NA	NA
Oak Red*	X	X	X	X
Oak Red Rift	X	X	X	X
Oak Red Rustic	X	X	NA	NA
Oak Red Value	X	X	X	X
Oak White Rift	X	X	NA	NA
Oak White	X	X	SX	X
Paint Grade*	X	X	X	X
Paint Grade MDF Panel*	X	X	X	X
Pine White Clear	X	X	X	X
Pine White Knotty*	X	X	X	X
Poplar	X	X	NA	NA
Walnut	X	X	X	X

*Available in 5/4 stock add 25%.

MINIMUM HEIGHT CHART FOR 5-PIECE COPE & STICK STYLE DRAWER FRONTS ONLY

Minimum Heights listed will allow for 1/2" flat area on center panel.

PANEL PROFILES	DF-301	DF-324	DF-401	DF-424
1/4" Panel	NA	NA	3"	3"
P-201	5 1/2"	5 1/2"	NA	NA
P-202	5 1/2"	5 1/2"	NA	NA
P-203	5 1/2"	5 1/2"	NA	NA
P-204	3"	3"	NA	NA
P-205	4 3/4"	4 3/4"	NA	NA
P-206	4 3/4"	4 3/4"	NA	NA
P-207	5 1/2"	5 1/2"	NA	NA
P-209	5 1/2"	5 1/2"	NA	NA
P-211	4 3/4"	4 3/4"	NA	NA
P-217	5 1/2"	5 1/2"	NA	NA
P-218	4 3/4"	4 3/4"	NA	NA

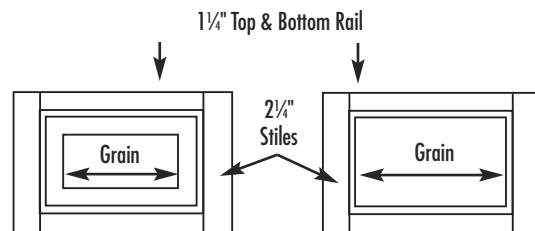

DF-301
(Raised Panel)
Minimum Width 7 1/4"

DF-401
(Flat Panel)
Minimum Width 7 1/4"

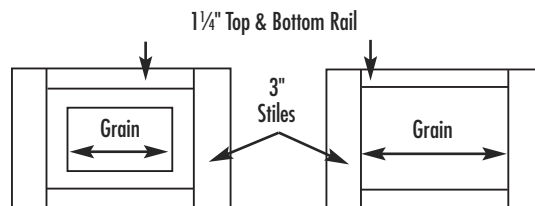

DF-324
(Raised Panel)
Minimum Width 8 3/4"

DF-424
(Flat Panel)
Minimum Width 8 3/4"

SEE CHART FOR MINIMUM HEIGHTS

GRAIN DIRECTION ON PANELS: Horizontal grain is standard. Vertical grain is available upon request.

See chart for minimum heights for 5-Piece Drawer Fronts.

Reduced panel profiles are available for 5-Piece Raised Panel Drawer Fronts, allowing for a smaller minimum height.

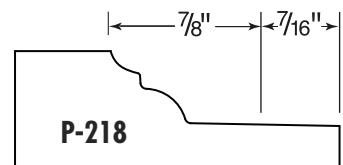
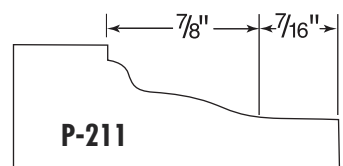
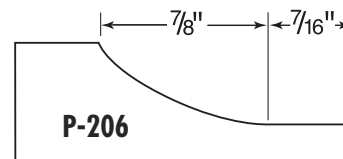
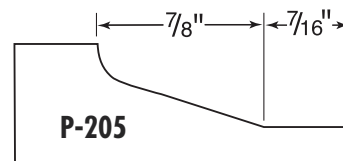

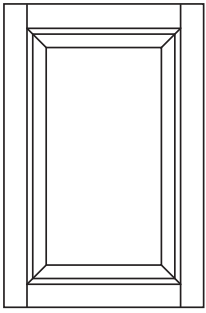

301
Price Group-100
Price Group-100G (Glass)
 7¼ x 7¼

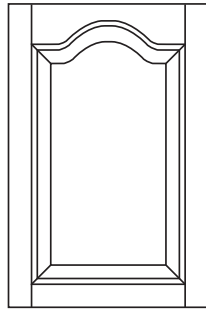

302
Price Group-101
Price Group-101G (Glass)
 8 x 9

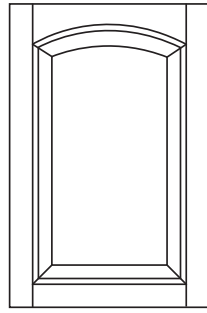

303
Price Group-101
Price Group-101G (Glass)
 8 x 8¾

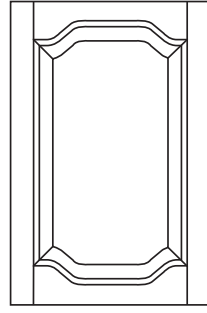

***304**
Price Group-102
Price Group-102G (Glass)
 8 x 12

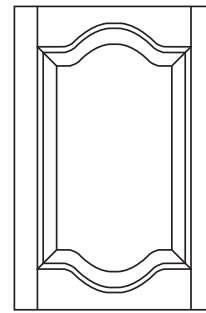

305
Price Group-102
Price Group-102G (Glass)
 8 x 12

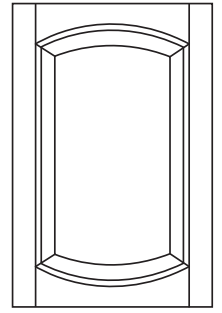

306
Price Group-102
Price Group-102G (Glass)
 8 x 10

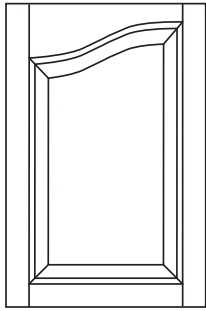

307L
Price Group-101
Price Group-101G (Glass)
 8 x 10¼

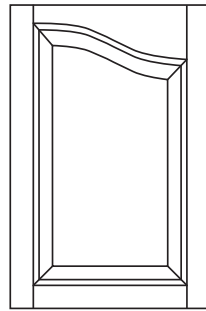

307R
Price Group-101
Price Group-101G (Glass)
 8 x 10¼

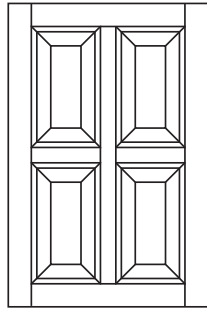

***308**
Price Group-105
Price Group-104G (Glass)
 12¼ x 12¼

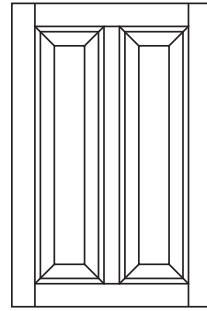

***309**
Price Group-103
Price Group-102G (Glass)
 12¼ x 7¼

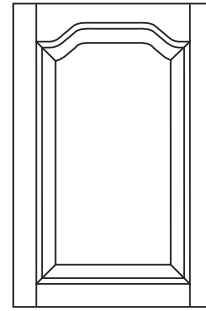

***310**
Price Group-101
Price Group-101G (Glass)
 8 x 9¼

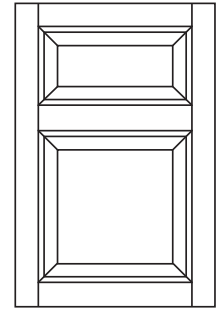

311
Price Group-103
Price Group-103G (Glass)
 7¼ x 15¾

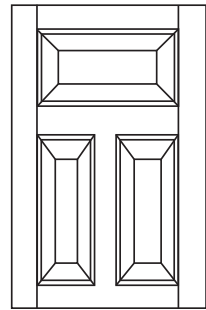

***315**
Price Group-105
Price Group-103G (Glass)
 12¼ x 15

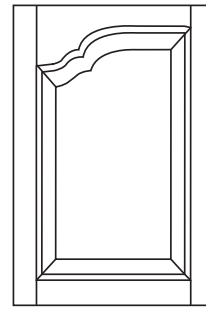

317L
Price Group-104
Price Group-102G (Glass)
 8 x 12

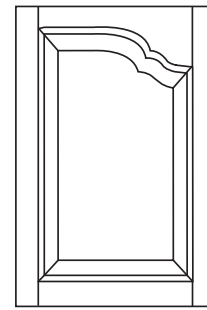

317R
Price Group-104
Price Group-102G (Glass)
 8 x 12

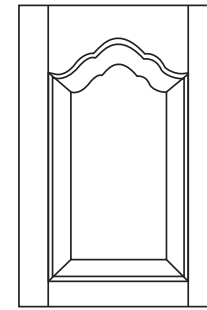

***318**
Price Group-102
Price Group-102G (Glass)
 8 x 10

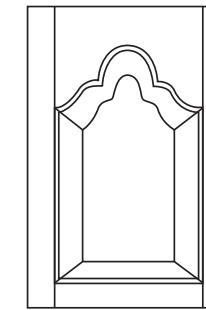

***319**
Price Group-104
Price Group-103G (Glass)
 8 x 12

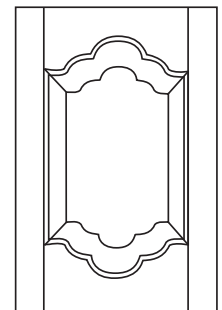

***320**
Price Group-104
Price Group-104G (Glass)
 8 x 12¾

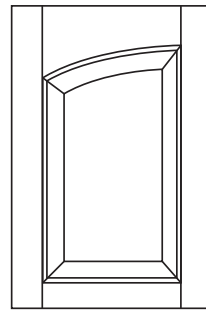

321L
Price Group-103
Price Group-102G (Glass)
 8 x 9

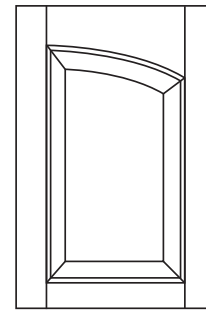

321R
Price Group-103
Price Group-102G (Glass)
 8 x 9

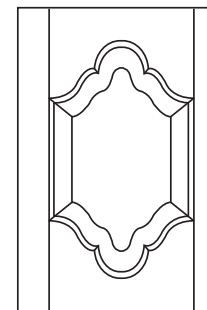

***322**
Price Group-105
Price Group-104G (Glass)
 8 x 17

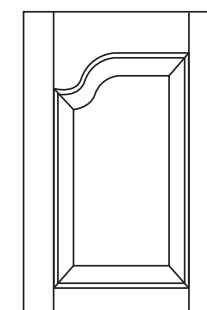

323L
Price Group-103
Price Group-101G (Glass)
 8 x 9

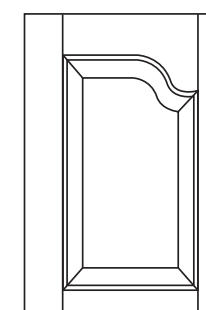

323R
Price Group-103
Price Group-101G (Glass)
 8 x 9

Note: Any door style can be made 2-panels high with a *square bottom panel* by adding a "5" after the 3 digit door style number.

Note: Any door style can be made 2-panels high with the bottom panel being exactly the same as the top panel by adding a "0" after the 3 digit door style number.

15 RAISED PANEL DOORS

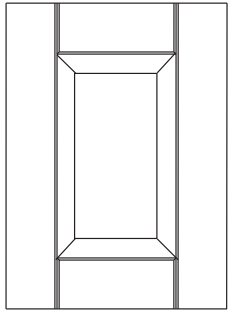

324
Price Group-101
Price Group-101G (Glass)
8¾ x 8¾
Shown w/SR-40

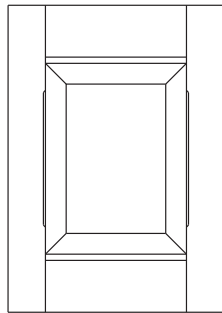

325 w/Bevel**
Price Group-105
Price Group-104G (Glass)
7¼ x 9¾ without bevel
7¼ x 11 with bevel

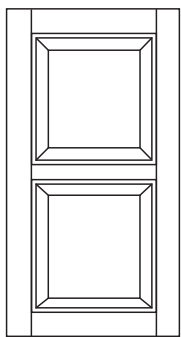

3015
Price Group-101
7¼ x 15¾

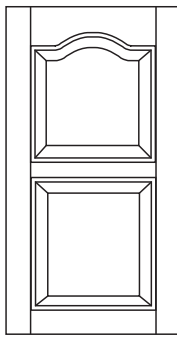

3025
Price Group-102
8 x 18

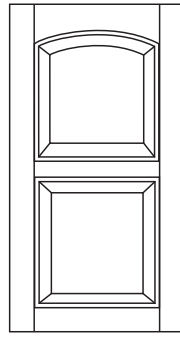

3035
Price Group-102
8 x 18

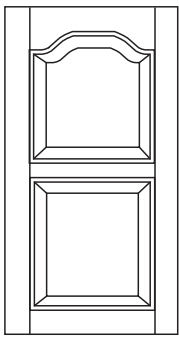

3105
Price Group-102
8 x 18

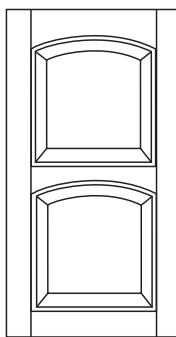

3030
Price Group-103
8 x 18

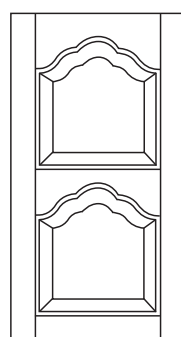

3180
Price Group-104
8 x 18

RAISED PANEL DOOR PRICING Note: One square foot minimum charge will apply.
Glass Door Pricing is on page 20.

*Available in 5/4 stock add 25%.

WOOD SPECIES	PRICE GROUP					
	100	101	102	103	104	105
Alder*	X	X	X	X	X	X
Alder Rustic	X	X	X	X	X	X
Ash White	X	X	X	X	X	X
Beech-European	X	X	X	X	X	X
Birch Red	X	X	X	X	X	X
Birch Value	X	X	X	X	X	X
Birch White	X	X	X	X	X	X
Butternut	X	X	X	X	X	X
Cedar Knotty	X	X	X	X	X	X
Cherry	X	X	X	X	X	X
Cherry Rustic	X	X	X	X	X	X
Cherry Value	X	X	X	X	X	X
Hickory*	X	X	X	X	X	X
Hickory Rustic	X	X	X	X	X	X
Lyptus	X	X	X	X	X	X
Mahogany African	X	X	X	X	X	X
Mahogany Genuine	X	X	X	X	X	X
Maple Hard White Value	X	X	X	X	X	X
Maple Hard White*	X	X	X	X	X	X
Maple Hard White Birdseye	X	X	X	X	X	X
Maple White Rustic	X	X	X	X	X	X
Maple Soft	X	X	X	X	X	X
Oak Red*	X	X	X	X	X	X
Oak Red Quarter Sawn	X	X	X	X	X	X
Oak Red Rift	X	X	X	X	X	X
Oak Red Rustic	X	X	X	X	X	X
Oak Red Value	X	X	X	X	X	X
Oak White	X	X	X	X	X	X
Oak White Quarter Sawn	X	X	X	X	X	X
Oak White Rift	X	X	X	X	X	X
Paint Grade*	X	X	X	X	X	X
Paint Grade - MDF Panel*	X	X	X	X	X	X
Pine White Clear	X	X	X	X	X	X
Pine White Knotty*	X	X	X	X	X	X
Poplar	X	X	X	X	X	X
Walnut	X	X	X	X	X	X

* Please Note: 304, 308, 309, 310, 315, 318, 319, 320, 322, 3105, 3185, 3100 and 3180 door styles ordered at or near the minimum sizes listed may not appear as the sketch shows.

**NOTE: 325 is available using the stile and rail profiles:

SR-50 (Combination of SR-10 on top and bottom rails with SR-30 on stiles)

SR-60 (Combination of SR-20 on top and bottom rails with SR-30 on stiles)

SR-90 (Combination of SR-70 on top and bottom rails with SR-30 on stiles)

Specify with or without bevel when ordering.

17 1/4" PANEL DOORS

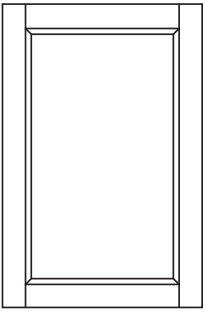

401
Price Group-200
7¼ x 5½

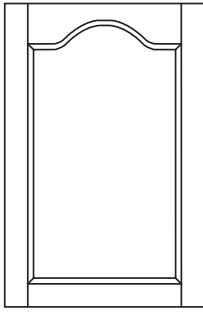

402
Price Group-201
8 x 7½

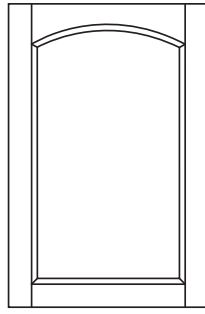

403
Price Group-201
8 x 6¾

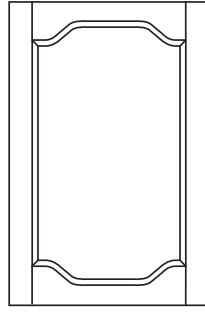

***404**
Price Group-203
8 x 9½

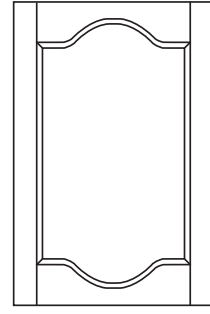

405
Price Group-203
8 x 9

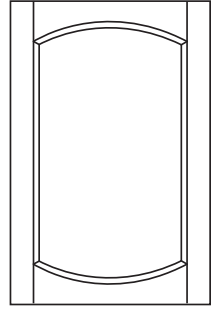

406
Price Group-203
8 x 9

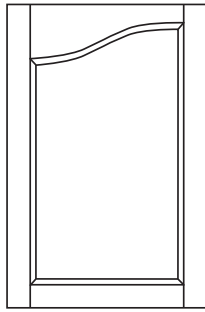

407L
Price Group-201
8 x 7¾

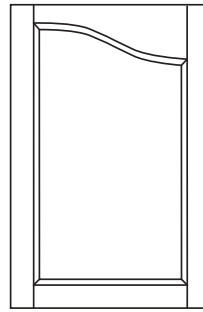

407R
Price Group-201
8 x 7¾

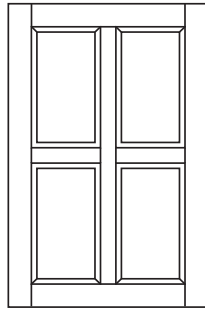

408
Price Group-204
12¾ x 8¾

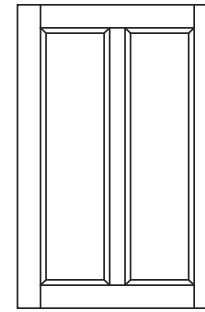

409
Price Group-202
8¾ x 7¼

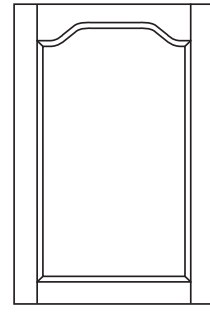

***410**
Price Group-201
8 x 9¼

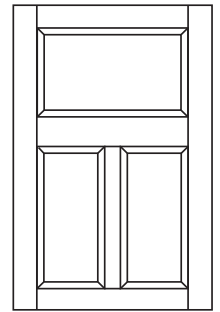

415
Price Group-203
8¾ x 10¾

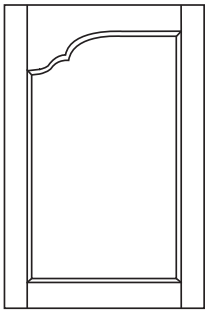

417L
Price Group-203
8 x 12

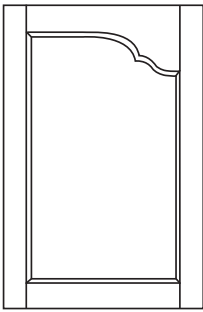

417R
Price Group-203
8 x 12

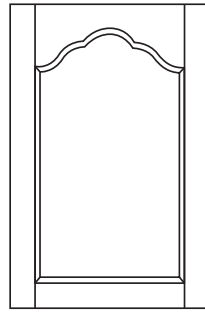

***418**
Price Group-202
8 x 10

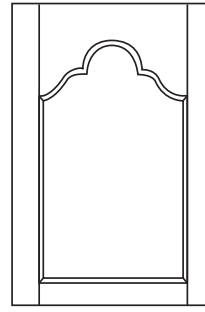

***419**
Price Group-203
8 x 12

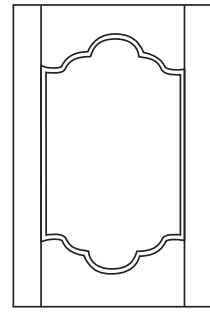

***420**
Price Group-204
8 x 12

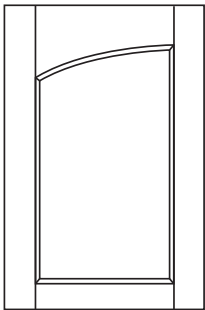

421L
Price Group-201
8 x 8

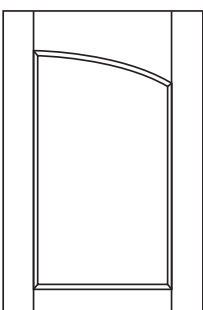

421R
Price Group-201
8 x 8

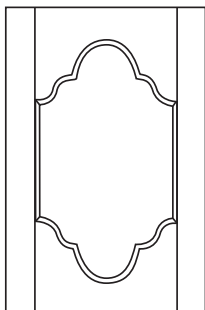

***422**
Price Group-204
8 x 15

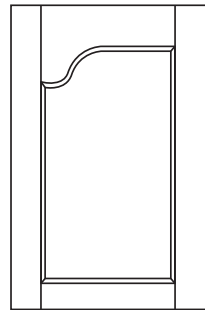

423L
Price Group-201
8 x 8

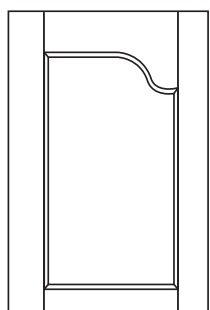

423R
Price Group-201
8 x 8

*** Please Note:**
404, 410, 418,
419, 420 and 422
door styles ordered
at or near the mini-
mum sizes listed
may not appear as
the sketch shows.

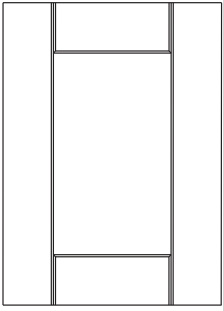

424
Shown with SR-40
Price Group-201
8 3/4 x 7

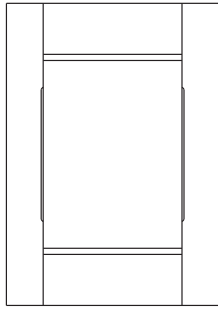

****425 w/Bevel**
Price Group-204
7 1/4 x 8 without bevel
7 1/4 x 11 with bevel

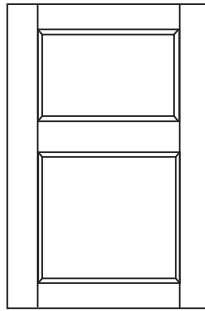

430
Price Group-202
7 1/4 x 10 3/4

****NOTE: 425 is available using the stile and rail profiles:**
SR-50 (Combination of SR-10 on top and bottom rails with SR-30 on stiles)
SR-60 (Combination of SR-20 on top and bottom rails with SR-30 on stiles)
SR-90 (Combination of SR-70 on top and bottom rails with SR-30 on stiles)
Specify with or without bevel when ordering.

Note: Any door style can be made 2-panels high with the bottom panel being *exactly the same as the top panel* by adding a "0" after the 3 digit door style number.

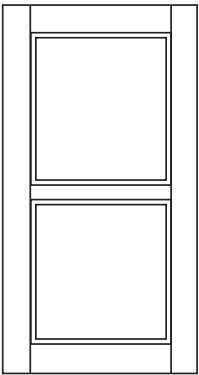

4015
Price Group-201
7 1/4 x 9

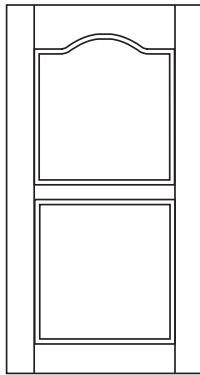

4025
Price Group-202
8 x 13

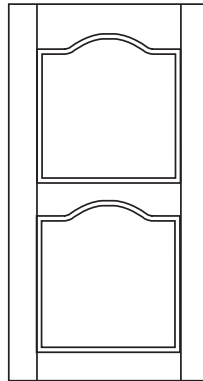

4020
Price Group-203
8 x 15

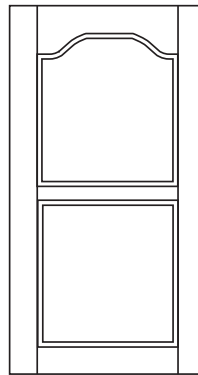

***4105**
Price Group-202
8 x 13

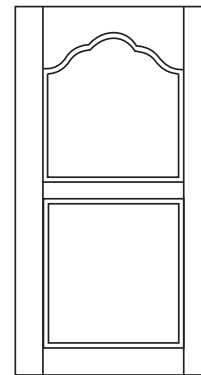

***4185**
Price Group-203
8 x 14

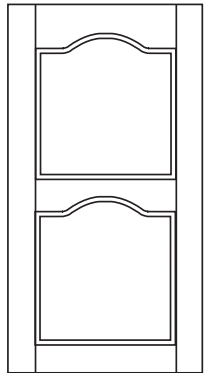

4020
Price Group-203
8 x 15

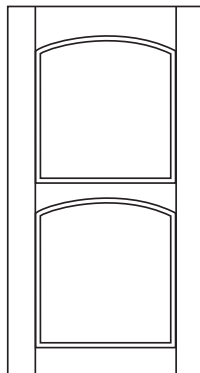

4030
Price Group-203
8 x 15

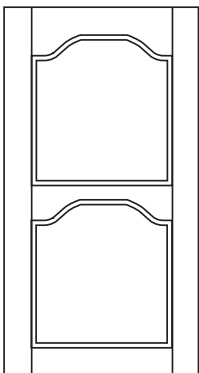

***4100**
Price Group-203
8 x 15

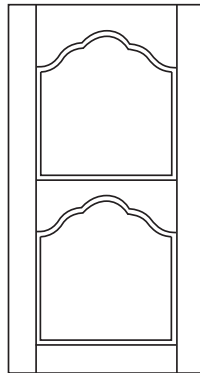

***4180**
Price Group-204
8 x 16

PRICE GROUP

WOOD SPECIES	200	201	202	203	204
Alder*	X	X	X	X	X
Ash White	X	X	X	X	X
Birch Value	X	X	X	X	X
Birch White	X	X	X	X	X
Cherry*	X	X	X	X	X
Cherry Value	X	X	X	X	X
Hickory*	X	X	X	X	X
Maple Hard White Value	X	X	X	X	X
Maple Hard White*	X	X	X	X	X
Maple Soft	X	X	X	X	X
Oak Red Quarter Sawn	X	X	X	X	X
Oak Red*	X	X	X	X	X
Oak Red Rift	X	X	X	X	X
Oak Red Value	X	X	X	X	X
Oak White	X	X	X	X	X
Paint Grade*	X	X	X	X	X
Paint Grade - MDF Panel	X	X	X	X	X
Pine White Clear	X	X	X	X	X
Pine White Knotty*	X	X	X	X	X
Walnut	X	X	X	X	X

*Available in 5/4 stock add 25%.

19 FRAMED GLASS DOORS

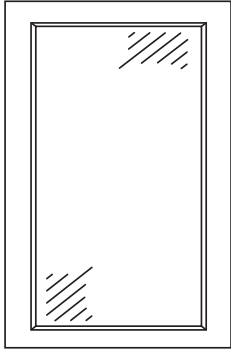

301-G
Price Group-100G
7¼ x 5½

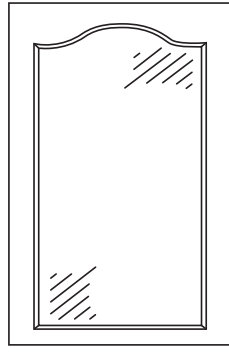

302-G
Price Group-101G
7½ x 7½

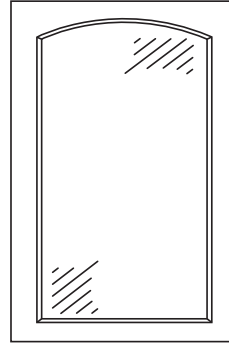

303-G
Price Group-101G
8 x 8¼

Note: Pricing Groups for all Glass Door styles are listed under each door sketch in the Raised Panel section and are listed with a "G".

- Any door style can be ordered as an open frame for glass by simply adding a "G" after the door style number. For example, a square raised panel door (style #301) is made open for glass by ordering it as a 301-G. Note: Glass is not supplied and all arched frames will require arched glass.
- Glass doors will also be prepared to receive glass in one of three ways:

1. Routing for Vinyl Retainer (see diagram A).

This is our standard procedure to prep for glass unless otherwise specified. The vinyl retainer will be supplied at no extra charge and is available in clear only.

DIAGRAM A

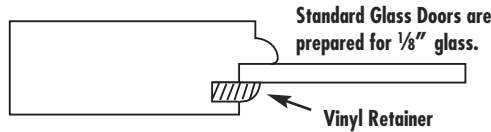

2. Routing out for Wood Retainer Strips (see diagram B).

These wood strips are made to fit the groove as shown and are sold in 5/8" wide x 1/4" thick x 8 foot lengths only. See page 59 for pricing.

DIAGRAM B

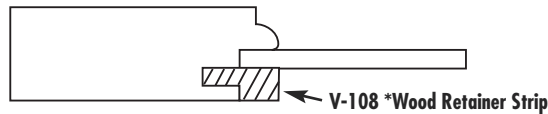

*Only available on stile and rail profiles that offer a "G" for routing.

3. Squaring Out the Back of the door will only be done if requested and will require glass clips (clips are not supplied.)

Note: arched doors that are squared out for glass will require an arched piece of glass to be used.

WIRE MESH GRILLS

Wire Mesh Grills are sold in 20" x 48" sheets. The wire grills can be cut to size and installed in the frames here using vinyl retainer. Any remaining portion will be shipped separately. Please specify on your order whether you want installed or full sheets sent.

CRIMP WIRE: DOUBLE – PATTERN NO. R321

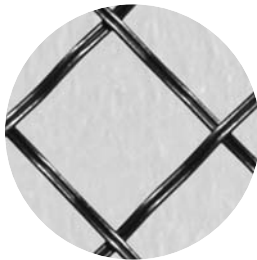

CRIMP: Double
WIRE: 1/16" x 1/8" Reeded Wire
DESCRIPTION: 1¼" Woven Diamond Mesh
FINISH: Oil Rubbed Bronze
PRICE: \$XXX.XX PER SHEET

CRIMP WIRE: DOUBLE – PATTERN NO. 121

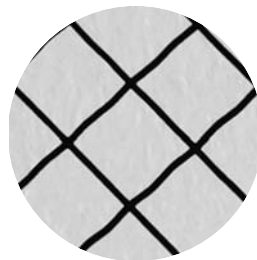

CRIMP: Double
WIRE: 1/16" Round Wire
DESCRIPTION: ¾" Woven Diamond Mesh
FINISH: Oil Rubbed Bronze
PRICE: XXX.XX PER SHEET

To figure the cost of a mullion door, use the price group noted for Glass Door.
Add \$X.XX per lite for the mullion charge. Note: Glass is not supplied.

For Example: Style 302-WG; Size 12" X 36" with 6 lites ordered in Red Oak would be:
 Price Group 101G at \$XX.XX x 3 sq ft = \$XX.XX
 6 Lites at \$X.XX each = \$XX.XX
TOTAL LIST COST = \$XX.XX

The standard placement of mullions will be to divide the opening equally as follows.

- 8" high to 22" high = 4 lites**
- 22 1/16" high to 38" high = 6 lites**
- 38 1/16" high to 60" high = 8 lites**

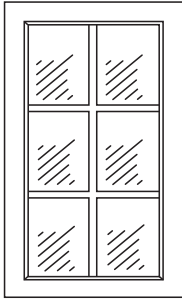

301-WG
 Price Group-100G
 PLUS \$X.XX Per Lite
 7 1/2 x 7 1/2

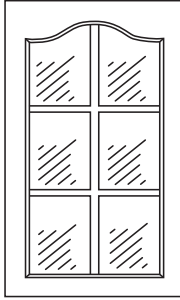

302-WG
 Price Group-101G
 PLUS \$X.XX Per Lite
 8 x 8 1/4

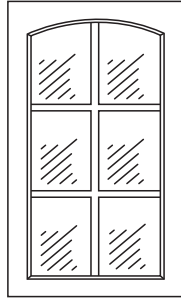

303-WG
 Price Group-101G
 PLUS \$X.XX Per Lite
 8 x 8 1/4

SPECIAL MULLION PLACEMENT STYLES

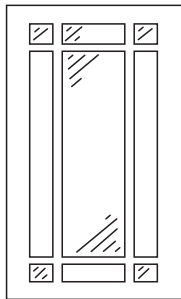

390-WG
 Price Group-100G
 PLUS \$X.XX Per Lite
 14 x 14

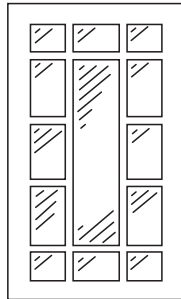

391-WG
 Price Group-100G
 PLUS \$X.XX Per Lite
 14 x 18

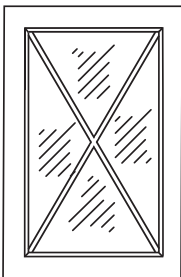

392-WG
 Price Group-100G
 PLUS \$XX.XX Per Lite
 14 x 14

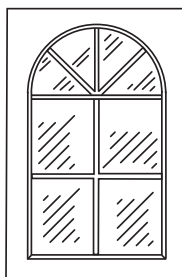

393-WG
 Price Group-105G
 PLUS \$X.XX Per Lite
 14 x 14

• Our Mullion Doors are not true divided lite doors. The mullions are cut out and profiled with the backsides routed to fit flush over the stile and rail profile on the door. They are held in place with high quality glue and are stapled on the backside for extra stability.

• Special mullion placements are available. Please send detailed drawings for price and availability.

*Available in 5/4 stock add 25%.

WOOD SPECIES	PRICE GROUP					
	100 G	101G	102G	103G	104G	105G
Alder*	X	X	X	X	X	X
Alder Rustic	X	X	X	X	X	X
Ash White	X	X	X	X	X	X
Beech European	X	X	X	X	X	X
Birch Red	X	X	X	X	X	X
Birch Value	X	X	X	X	X	NA
Birch White	X	X	X	X	X	X
Butternut	X	X	X	X	X	X
Cedar Knotty	X	X	X	X	X	X
Cherry*	X	X	X	X	X	X
Cherry Rustic	X	X	X	X	X	X
Cherry Value	X	X	X	X	X	NA
Hickory*	X	X	X	X	X	X
Hickory Rustic	X	X	X	X	X	X
Lyptus	X	X	X	X	X	X
Mahogany Genuine	X	X	X	X	X	X
Mahogany African	X	X	X	X	X	X
Maple White Rustic	X	X	X	X	X	X
Maple Hard White*	X	X	X	X	X	X
Maple Hard White Birdseye	X	X	X	X	X	X
Maple Hard White Value	X	X	X	X	X	NA
Maple Soft	X	X	X	X	X	X
Oak Red Quarter Sawn	X	X	X	X	X	X
Oak White Quarter Sawn	X	X	X	X	X	X
Oak Red*	X	X	X	X	X	X
Oak Red Rift	X	X	X	X	X	X
Oak Red Rustic	X	X	X	X	X	NA
Oak Red Value	X	X	X	X	X	NA
Oak White Rift	X	X	X	X	X	X
Oak White	X	X	X	X	X	X
Paint Grade*	X	X	X	X	X	X
Pine White Clear	X	X	X	X	X	X
Pine White Knotty*	X	X	X	X	X	X
Poplar	X	X	X	X	X	X
Walnut	X	X	X	X	X	X

MULLIONS ADD \$X.XX PER LITE UNLESS OTHERWISE SPECIFIED

MULLION DESIGNS AND SPECIFICATIONS

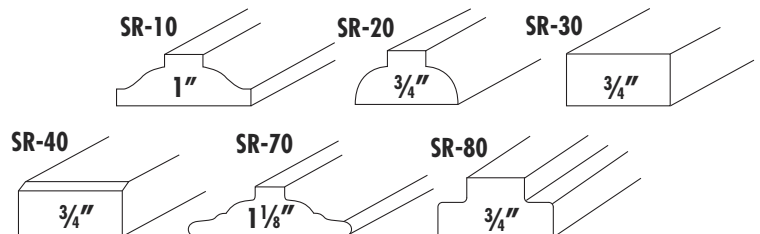

• Our Mullion Doors are not true divided lite doors. The mullions are cut out and profiled with the backsides routed to fit flush over the stile and rail profile on the door. They are held in place with high quality glue and are stapled on the backside for extra stability.





• Special mullion placements are available. Please send detailed drawings for price and availability.

21 MITRED DOORS AND DRAWER FRONTS

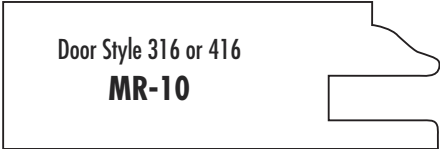
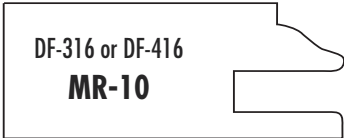
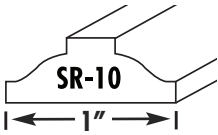
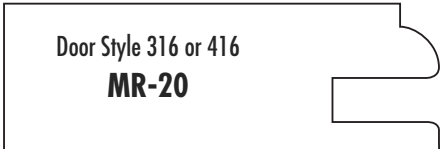
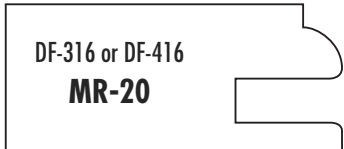
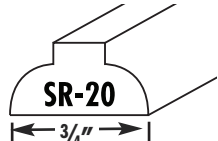
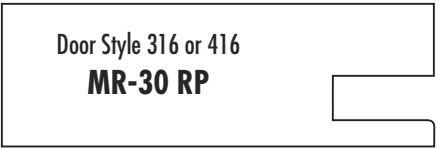
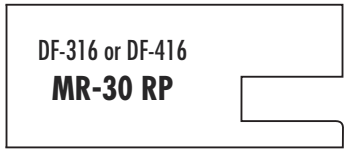
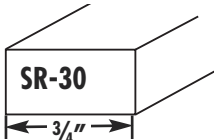
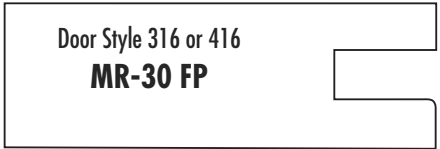
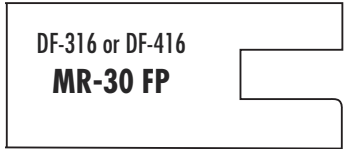
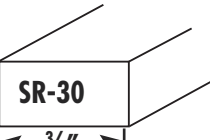
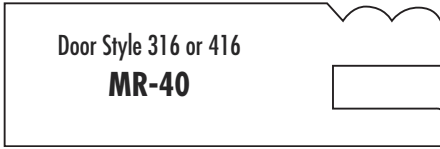
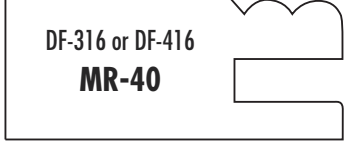
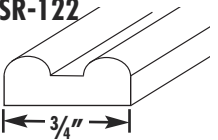
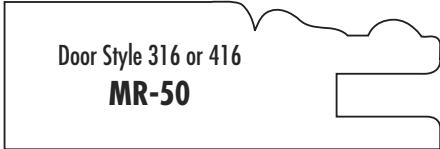
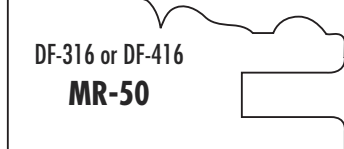
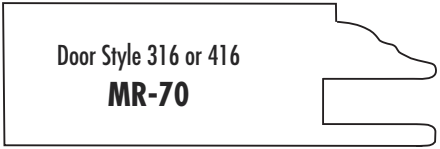
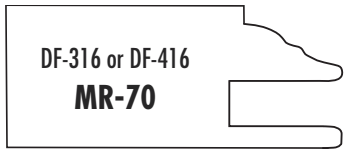
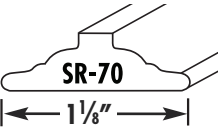
ORDERING INFORMATION

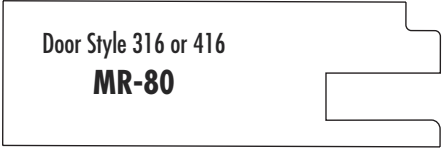
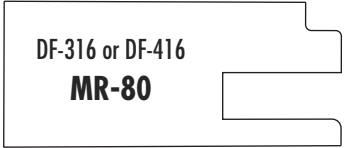
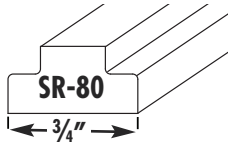
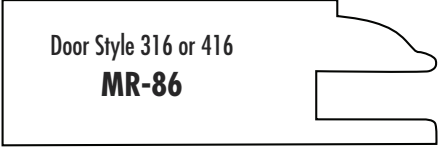
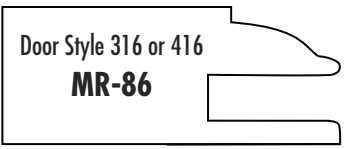

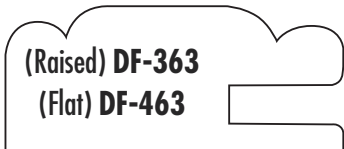
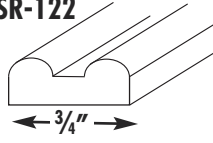
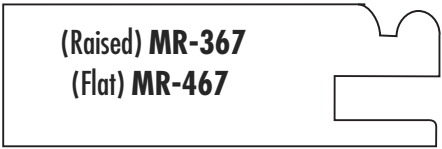
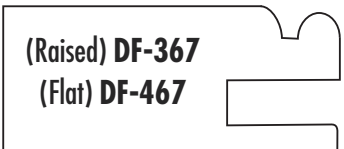
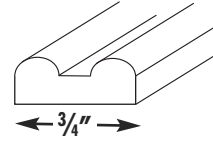
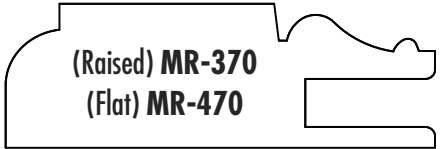
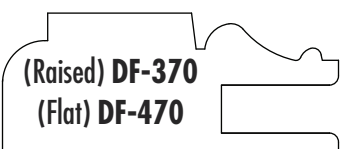
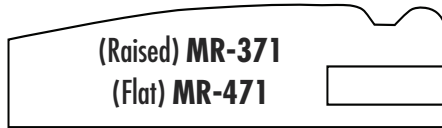

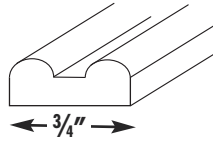

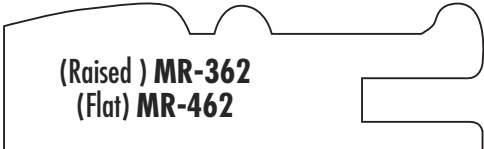
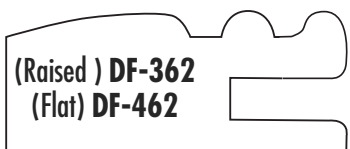
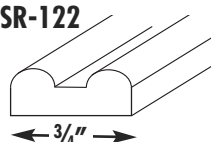

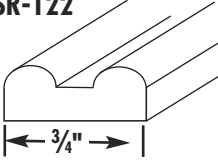
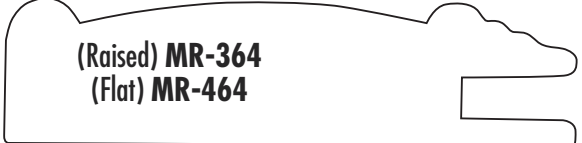
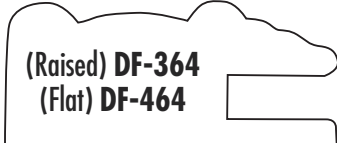
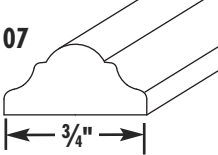

1. MR-10, MR-20, MR-30, MR-40, MR-50 and MR-368 can use any outside edge profile found on page 10 except: E-102, E-103, E-107, E-108, E-113 and E-116.
2. 2 1/2" wide center rails are available on all mitred style doors with the exception of MR-50, MR-366 and MR-375.
3. Mitred doors will expand and contract in response to environmental conditions. Our doors are made with a gap tolerance of up to .010 on the inside corner to allow for this expansion and contraction. Mitred doors will not be warranted against joint separation that occurs due to high or low humidity conditions.
4. A painted finish is not recommended on mitred doors.

2-1/4" WIDE FRAME	1-3/4" WIDE DRAWER FRONT FRAMES	GLASS & MULLION
<p>MINIMUM SIZE: Raised Panel 7-3/8" x 7-3/8" 1/4" Flat Panel 5-1/2" x 5-1/2"</p> <p>300 Series (Solid Wood Panel) are PRICE GROUP 300 400 Series (1/4" Flat Panel) are PRICE GROUP 301 GLASS (Frames Only) are PRICE GROUP 302</p>	<p>MINIMUM SIZE: Raised Panel 6-1/2" x 6-1/2" 1/4" Flat Panel 4 1/2" x 4 1/2"</p> <p>300 Series (Solid Wood Panel) / PRICE GROUP 300 400 Series (1/4" Flat Panel) / PRICE GROUP 301 GLASS (Frames Only) / PRICE GROUP 302</p>	<p>GLASS PRICE GROUP 302 MULLIONS ADD \$6.65 per Lite. *Mullion style is shown for each door.</p>
<p>Door Style 316 or 416 MR-10</p> 	<p>DF-316 or DF-416 MR-10</p> 	 <p>SR-10 1"</p>
<p>Door Style 316 or 416 MR-20</p> 	<p>DF-316 or DF-416 MR-20</p> 	 <p>SR-20 3/4"</p>
<p>Door Style 316 or 416 MR-30 RP</p> 	<p>DF-316 or DF-416 MR-30 RP</p> 	 <p>SR-30 3/4"</p>
<p>Door Style 316 or 416 MR-30 FP</p> 	<p>DF-316 or DF-416 MR-30 FP</p> 	 <p>SR-30 3/4"</p>
<p>Door Style 316 or 416 MR-40</p> 	<p>DF-316 or DF-416 MR-40</p> 	<p>SR-122</p>  <p>3/4"</p>
<p>Door Style 316 or 416 MR-50</p> 	<p>DF-316 or DF-416 MR-50</p> 	<p>NA</p>
<p>Door Style 316 or 416 MR-70</p> 	<p>DF-316 or DF-416 MR-70</p> 	 <p>SR-70 1 1/8"</p>

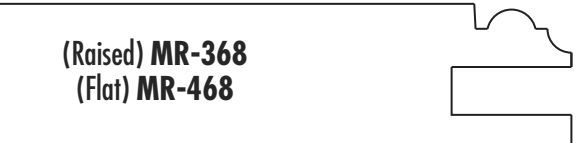
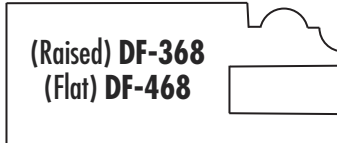
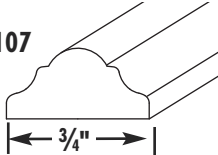
2-1/4" WIDE FRAME	1-3/4" WIDE DRAWER FRONT FRAMES	GLASS & MULLION
<p>MINIMUM SIZE: Raised Panel 7-3/8" x 7-3/8" 1/4" Flat Panel 5-1/2" x 5-1/2"</p> <p>300 Series (Solid Wood Panel) are PRICE GROUP 300 400 Series (1/4" Flat Panel) are PRICE GROUP 301 GLASS (Frames Only) are PRICE GROUP 302</p>	<p>MINIMUM SIZE: Raised Panel 6-1/2" x 6-1/2" 1/4" Flat Panel 4 1/2" x 4 1/2"</p> <p>300 Series (Solid Wood Panel) / PRICE GROUP 300 400 Series (1/4" Flat Panel) / PRICE GROUP 301 GLASS (Frames Only) / PRICE GROUP 302</p>	<p>GLASS PRICE GROUP 302 MULLIONS ADD \$X.XX per Lite. *Mullion style is shown for each door.</p>
<p>Door Style 316 or 416 MR-80</p> 	<p>DF-316 or DF-416 MR-80</p> 	 <p>SR-80 ← 3/4" →</p>
<p>Door Style 316 or 416 MR-86</p> 	<p>Door Style 316 or 416 MR-86</p> 	<p>NA</p>
<p>(Raised) MR-363 (Flat) MR-463</p> 	<p>(Raised) DF-363 (Flat) DF-463</p> 	<p>SR-122</p>  <p>← 3/4" →</p>
<p>(Raised) MR-367 (Flat) MR-467</p> 	<p>(Raised) DF-367 (Flat) DF-467</p> 	<p>SR-122</p>  <p>← 3/4" →</p>
<p>(Raised) MR-370 (Flat) MR-470</p> 	<p>(Raised) DF-370 (Flat) DF-470</p> 	<p>NA</p>
<p>(Raised) MR-371 (Flat) MR-471</p> 	<p>(Raised) DF-371 (Flat) DF-471</p> 	<p>SR-122</p>  <p>← 3/4" →</p>

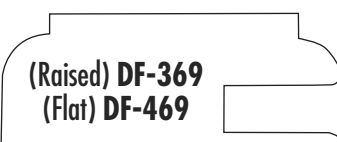
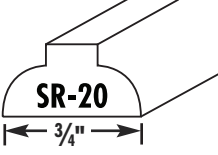
2-1/2" WIDE FRAME	1 -3/4" WIDE DRAWER FRONT FRAMES	GLASS & MULLION
<p>MINIMUM SIZE: Raised Panel 7-7/8" x 7-7/8" 1/4" Flat Panel 6" x 6"</p> <p>300 Series (Solid Wood Panel) are PRICE GROUP 303 400 Series (1/4" Flat Panel) are PRICE GROUP 304 GLASS (Frames Only) are PRICE GROUP 305</p>	<p>MINIMUM SIZE: Raised Panel 6-1/2" x 6-1/2" 1/4" Flat Panel 4-1/2" x 4-1/2"</p> <p>300 Series (Solid Wood Panel) / PRICE GROUP 300 400 Series (1/4" Flat Panel) / PRICE GROUP 301 GLASS (Frames Only) / PRICE GROUP 302</p>	<p>GLASS PRICE GROUP 302 MULLIONS ADD \$X.XX per Lite. *Mullion style is shown for each door.</p>
<p>(Raised) MR-362 (Flat) MR-462</p> 	<p>(Raised) DF-362 (Flat) DF-462</p> 	<p>SR-122</p>  <p>← 3/4" →</p>

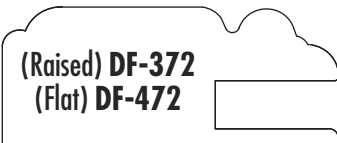
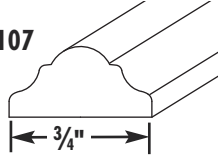
23 MITRED DOORS AND DRAWER FRONTS PRICING

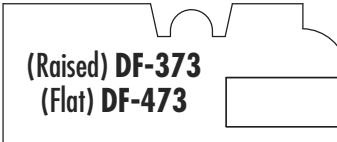
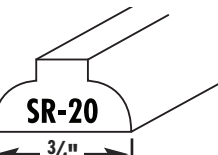
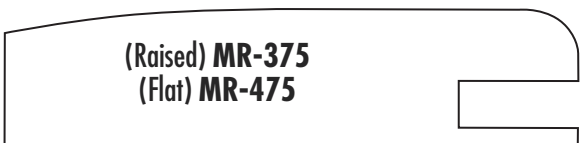
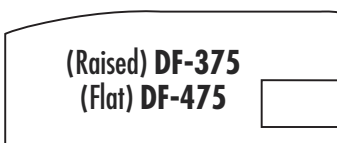
3" WIDE FRAME	1 -3/4" WIDE DRAWER FRONT FRAMES	GLASS & MULLION
<p>MINIMUM SIZE: Raised Panel 8-7/8" x 8-7/8" 1/4" Flat Panel 7" x 7"</p> <p>300 Series (Solid Wood Panel) are PRICE GROUP 306 400 Series (1/4" Flat Panel) are PRICE GROUP 307 GLASS (Frames Only) are PRICE GROUP 308</p>	<p>MINIMUM SIZE: Raised Panel 6-1/2" x 6-1/2" 1/4" Flat Panel 4-1/2" x 4-1/2"</p> <p>300 Series (Solid Wood Panel) / PRICE GROUP 300 400 Series (1/4" Flat Panel) / PRICE GROUP 301 GLASS (Frames Only) / PRICE GROUP 302</p>	<p>GLASS PRICE GROUP 302 MULLIONS ADD \$X.XX per Lite. *Mullion style is shown for each door.</p>
 <p>(Raised) MR-360 (Flat) MR-460</p>	 <p>(Raised) DF-360 (Flat) DF-460</p>	<p>SR-122</p> 
 <p>(Raised) MR-364 (Flat) MR-464</p>	 <p>(Raised) DF-364 (Flat) DF-464</p>	<p>SR-107</p> 
 <p>(Raised) MR-366 (Flat) MR-466</p>	<p>NA</p>	<p>NA</p>
 <p>(Raised) MR-368 (Flat) MR-468</p>	 <p>(Raised) DF-368 (Flat) DF-468</p>	<p>SR-107</p> 
 <p>(Raised) MR-369 (Flat) MR-469</p>	 <p>(Raised) DF-369 (Flat) DF-469</p>	<p>SR-20</p> 
 <p>(Raised) MR-372 (Flat) MR-472</p>	 <p>(Raised) DF-372 (Flat) DF-472</p>	<p>SR-107</p> 
 <p>(Raised) MR-373 (Flat) MR-473</p>	 <p>(Raised) DF-373 (Flat) DF-473</p>	<p>SR-20</p> 
 <p>(Raised) MR-375 (Flat) MR-475</p>	 <p>(Raised) DF-375 (Flat) DF-475</p>	<p>NA</p>

Note: One square foot minimum charge will apply on doors. 1/2 sq ft minimum charge will apply on drawer fronts.

WOOD SPECIES	PRICE GROUP (As listed on pages 21-23)								
	300	301	302*	303	304	305*	306	307	308*
Alder	X	X	X	X	X	X	X	X	X
Alder Rustic	X	NA	X	NA	NA	NA	N.A	NA	NA
Ash White	X	X	X	X	X	X	X	X	X
Beech European	X	NA	X	X	NA	X	X	NA	X
Birch Red	X	NA	X	X	NA	X	X	NA	X
Birch Value	X	X	X	X	X	X	X	X	X
Birch White	X	X	X	X	X	X	X	X	X
Butternut	X	NA	X	X	NA	X	X	NA	X
Cedar Knotty	X	NA	X	X	NA	X	X	NA	X
Cherry	X	X	X	X	X	X	X	X	X
Cherry Rustic	X	NA	X	NA	NA	NA	NA	NA	NA
Cherry Value	X	X	X	X	X	X	X	X	X
Hickory	X	X	X	X	X	X	X	X	X
Hickory Rustic	X	NA	X	NA	NA	NA	NA	NA	NA
Lyptus	X	NA	X	X	NA	X	X	NA	X
Mahogany African	X	NA	X	X	NA	X	X	NA	X
Mahogany Genuine	X	NA	X	X	NA	X	X	NA	X
Maple Hard White	X	X	X	X	X	X	X	X	X
Maple Hard White Birdseye	X	NA	X	X	NA	X	X	NA	X
Maple Hard White Value	X	X	X	X	X	X	X	X	X
Maple White Rustic	X	NA	X	NA	NA	NA	NA	NA	NA
Maple Soft	X	X	X	X	X	X	X	X	X
Oak Red	X	X	X	X	X	X	X	X	X
Oak Red Quarter Sawn	X	X	X	X	X	X	X	X	X
Oak Red Rift	X	X	X	X	X	X	X	X	X
Oak Red Rustic	X	NA	X	NA	NA	X	NA	NA	NA
Oak Red Value	X	X	X	X	X	X	X	X	X
Oak White	X	X	X	X	X	X	X	X	X
Oak White Quarter Sawn	X	NA	X	X	NA	X	X	NA	X
Oak White Rift	X	NA	X	X	NA	X	X	NA	X
Paint Grade	X	X	X	X	X	X	X	X	X
Paint Grade - MDF Panel	X	X	NA	X	X	NA	X	X	NA
Pine White Clear	X	X	X	X	X	X	X	X	X
Pine White Knotty	X	X	X	NA	NA	NA	NA	NA	NA
Poplar	X	NA	X	X	NA	X	X	NA	X
Walnut	X	X	X	X	X	X	X	X	X

*Add \$X.XX per lite for Mullion Doors.

Add \$X.XX per sq ft to the cost listed above for Center Rails on doors 48" high or more.

25 APPLIED MOULDING DOORS AND DRAWER FRONTS

V-100 and V-109 APPLIED MOULDING

The application of these mouldings require a minimum of 1½" frame width using ONLY Stile and Rail profile SR-30RP for Cope & Stick or 1¾" frame using ONLY the MR-30RP for Mitred style. Panel Profile options for use with the V-100 or V-109 moulding are listed below. Most of the Outside Edge profiles shown on page 10 will work although some of the wider edges may interfere with the moulding. Check with customer service for more information on outside edge limitations.

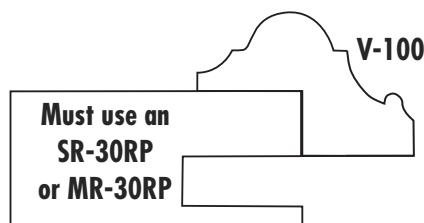
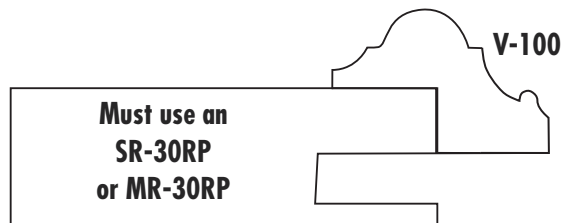
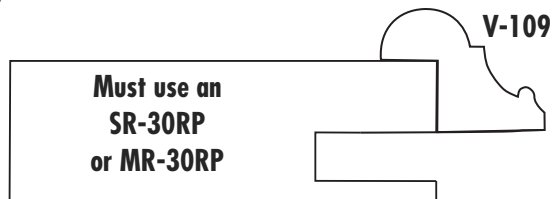

PANEL PROFILES AVAILABLE

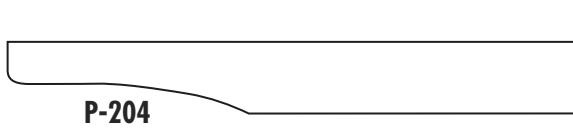

V-102 and SR-107 APPLIED MOULDING

Both the V-102 and the SR-107 are applied at 1/8" distance from the edge as shown. Therefore, these mouldings will require a minimum of 1½" to 2" wide frame width depending on the width of the outside edge selected from page 10. Check with Customer Service for more information on outside edge profile limitations.

Any Stile and Rail profiles shown on page 9 will work with these mouldings in either Cope & Stick or Mitred construction.

Any Panel Profile shown on page 8 will work for doors or drawer fronts with additional Reduced Panel Profiles shown on page 13 available for drawer fronts that are 5½" high or less.

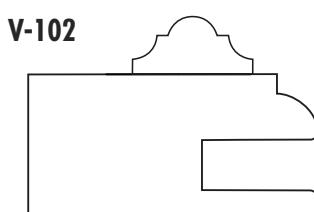
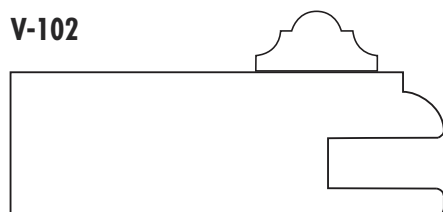
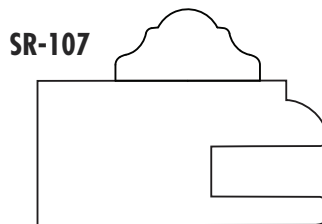
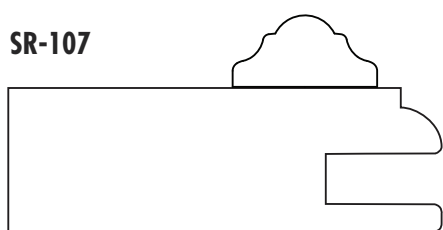

V-105 APPLIED MOULDING

- The application of the V-105 moulding requires that only the SR-30FP Stile and Rail profile be used for Cope & Stick or MR-30FP for Mitred style.
- Panel Profile options for use with-105 moulding are listed below.
- Any Outside Edge profile shown on page 10 will work with the V-105.

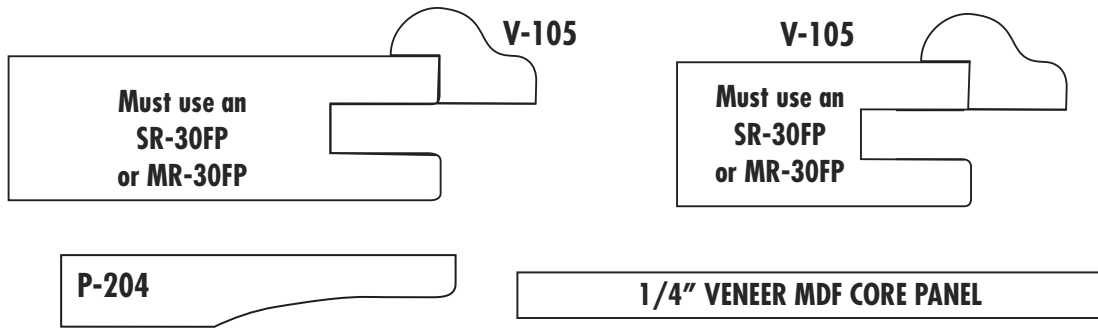

V-106 AND V-112 APPLIED MOULDING

- Each of the V-106 and V-112 mouldings are placed in a 3/8" wide notch in the mitred frame of the doors and drawer fronts as shown below.
- There are no other outside edge or stile & rail options available on these doors.
- Any Panel Profile shown on page 8 will work for doors or drawer fronts. Additional Reduced Panel Profiles on page 13 are available for drawer fronts that are 5 1/2" high or less.
- The optional Corner Peg application is available using the V-106 or the V-112 and will have a 1/4" x 1/4" square peg placed in all four corners so the moulding will butt into the pegs (as shown).

ALL PANEL PROFILES SHOWN ON PAGE 8 ARE AVAILABLE

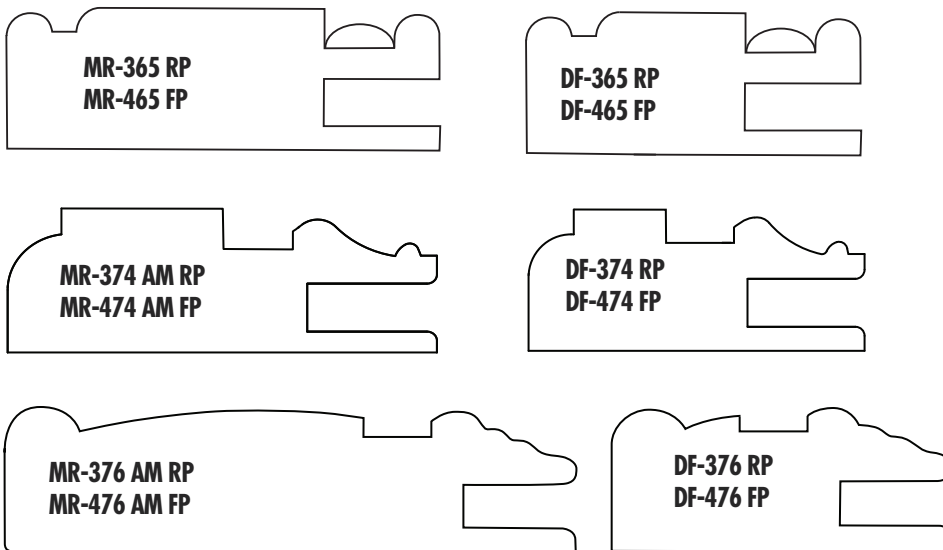

CORNER PEG APPLICATION



V-112CP is shown on door style 474AM

V-106
3/8" Rope



V-112
3/8" Bead



QUARTER CIRCLE DOOR PRICING *Per square foot*

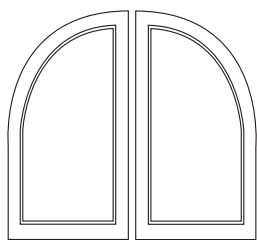

451L 451R
8 x 8 8 x 8
Price Group-504

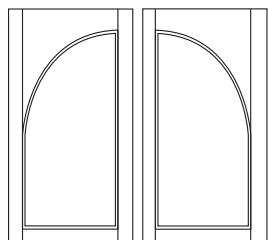

450L 450R
8 x 8 8 x 8
Price Group-503

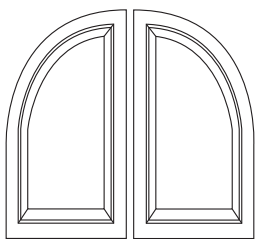

351L 351R
8 x 8 8 x 8
Price Group-501

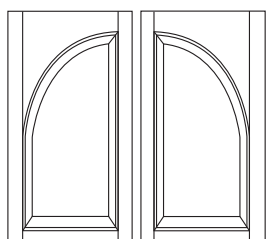

350L 350R
8 x 8 8 x 8
Price Group-500

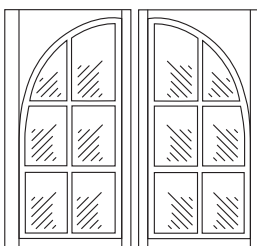

350L-WG 350R-WG
8 x 8 8 x 8
Price Group-502
With Square Mullions
Add \$X.XX Per Lite

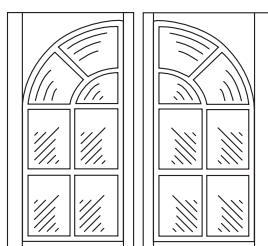

350L-WG 350R-WG
8 x 8 8 x 8
Price Group-502
With Arched Mullions
Add \$XX.XX Per Lite

- Each radius is measured from the inside of the door.
- All outside edge profiles listed on page 10 are available on door styles 450, 350, and 350-WG.
- Only outside profiles E-101, E-103, E-104, E-105, E-106, E-108, E-110, E-114, E-115, E-116, E-117, E-118, E-121, E-123, E-124, and E-126 are available on door styles 451 and 351.
- Stile and Rail profiles available: SR-10, SR-20, SR-30RP, SR-30FP and SR-70.
- The width cannot exceed the height of the door. Mullions may not line up evenly when widths and heights vary on a group of doors.

WOOD SPECIES	PRICE GROUP				
	500	501	502	503	504
Alder*	X	X	X	X	X
Alder Rustic	X	X	X	NA	NA
Ash White	X	X	X	X	X
Beech European	X	X	X	NA	NA
Birch Red	X	X	X	NA	NA
Birch White	X	X	X	X	X
Butternut	X	X	X	NA	NA
Cedar Knotty	X	X	X	NA	NA
Cherry*	X	X	X	X	X
Cherry Rustic	X	X	X	NA	NA
Hickory*	X	X	X	X	X
Hickory Rustic	X	X	X	NA	NA
Lyptus	X	X	X	NA	NA
Mahogany African	X	X	X	NA	NA
Mahogany Genuine	X	X	X	NA	NA
Maple Hard White	X	X	X	X	X
Maple Hard White Birdseye	X	X	X	NA	NA
Maple White Rustic	X	X	X	NA	NA
Maple Soft	X	X	X	X	X
Oak Red*	X	X	X	X	X
Oak Red Quarter Sawn	X	X	X	X	X
Oak Red Rift	X	X	X	X	X
Oak Red Rustic	X	X	NA	NA	NA
Oak White	X	X	X	X	X
Oak White Quarter Sawn	X	X	X	NA	NA
Oak White Rift	X	X	X	NA	NA
Paint Grade*	X	X	X	X	X
Paint Grade MDF Panel	X	X	NA	X	X
Pine White Clear	X	X	X	X	X
Pine White Knotty*	X	X	X	X	X
Poplar	X	X	X	NA	NA
Walnut	X	X	X	X	X

*Available in 5/4 stock add 25%.

- Panel Profiles Available: P-201, P-202, P-203, P-207, P-209, P-210, P-211 and P-217.
- STYLE 350WG add \$15.15 per lite for Arched Mullions. (Available only on SR-10, SR-20 and SR-30.
- Add \$6.65 per lite for Square Mullions.

SOLID WOOD DOORS PRICING

Note: One square foot minimum charge will apply.

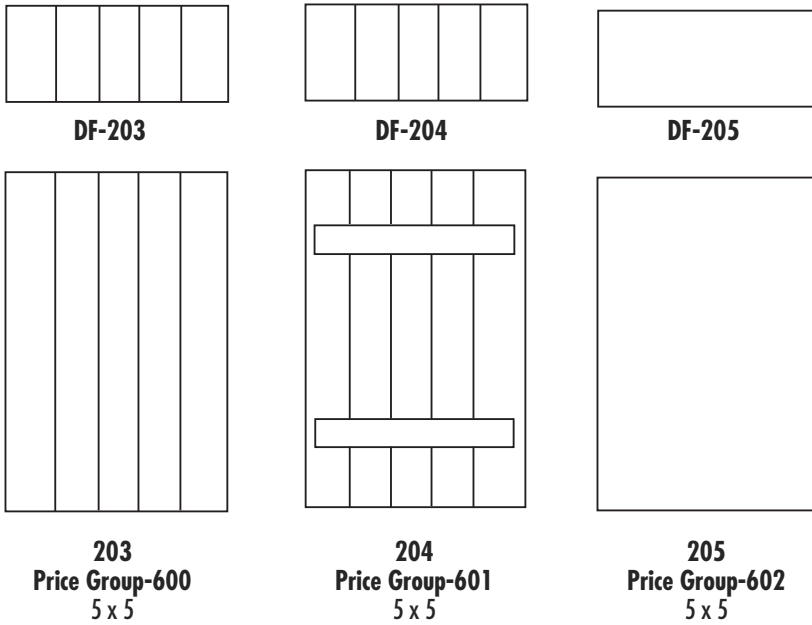

DOOR STYLE DESCRIPTIONS:

#203 and #204 will be grooved every 2 1/8" on center. Each style has batten strips that are 3/4" thick x 2" wide. The battens will be placed 2" in from the edge and 4" from the top and bottom on style #203 and #205.

Style #204 will have the battens on the front side of the door and placed 3/4" in from the edge and 3" from the top and bottom.

Style #205 is a slab door with battens and a routed edge profile of your choice. There will be no grooves on the face or relief cuts on the back side.

DRAWER FRONTS:

DF-203, DF-204 and DF-205 will have vertical grain direction unless otherwise specified.

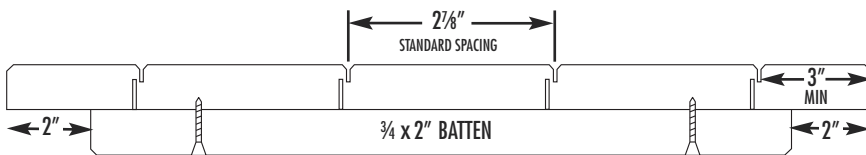

PRICE GROUP

WOOD SPECIES	PRICE GROUP		
	600	601	602
Alder*	X	X	X
Alder Rustic	X	X	X
Ash White	X	X	X
Beech European	X	X	X
Birch Red	X	X	X
Birch Value	X	X	X
Birch White	X	X	X
Butternut	X	X	X
Cedar Knotty	X	X	X
Cherry*	X	X	X
Cherry Rustic	X	X	X
Cherry Value	X	X	X
Hickory*	X	X	X
Hickory Rustic	X	X	X
Lyptus	X	X	X
Mahogany African	X	X	X
Mahogany Genuine	X	X	X
Maple Hard White*	X	X	X
Maple Hard White Birdseye	X	X	X
Maple Hard White Value	X	X	X
Maple White Rustic	X	X	X
Maple Soft	X	X	X
Oak Red*	X	X	X
Oak Red Quarter Sawn	X	X	X
Oak Red Rift	X	X	X
Oak Red Rustic	X	X	X
Oak Red Value	X	X	X
Oak White	X	X	X
Oak White Quarter Sawn	X	X	X
Oak White Rift	X	X	X
Paint Grade*	X	X	X
Pine White Clear	X	X	X
Pine White Knotty*	X	X	X
Poplar	X	X	X
Walnut	X	X	X

*Available in 5/4 stock add 25%.

31 MDF VENEER DOORS

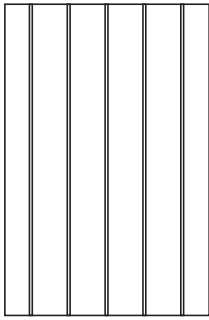

505
Price Group-700
7 x 7

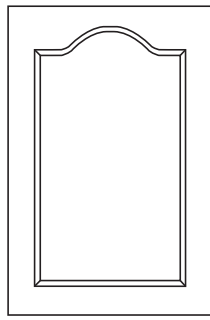

506
Price Group-700
8 x 8

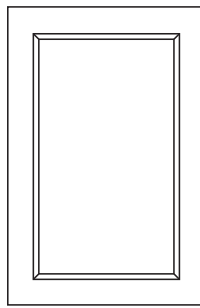

507
Price Group-700
6 x 6

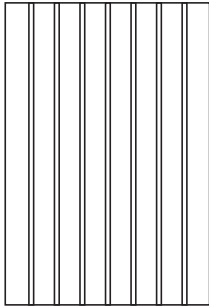

508
Price Group-700
6 x 6



509
Price Group-701
No Minimum

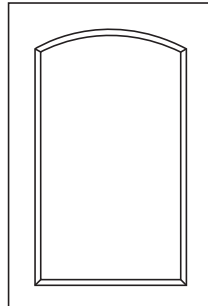

512
Price Group-700
8 x 8

- Vertical grain direction on doors & drawer fronts is standard.
- Add \$X.XX/sq. ft. for grain-matched doors & drawer fronts. Must specify **Grain Matched** on order and supply layout.
- Stained edges available: E-103 or Taped
- Painted edges available: E-104, E-105, E-106, E-108, E-114 and E-118

	PRICE GROUP	
	700	701
P/S ALDER	X	X
P/S OAK	X	X
P/S MAPLE	X	X
P/S CHERRY	X	X
P/S HICKORY	X	X
P/S KNOTTY PINE	X	X
U/W BIRCH	X	X
MDF	X	X

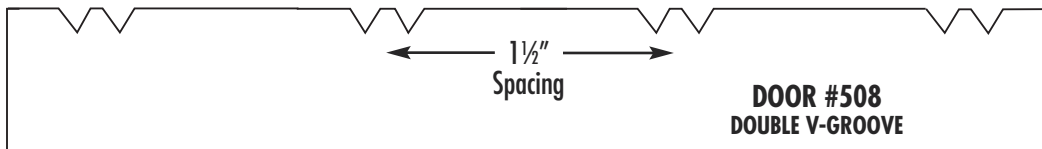
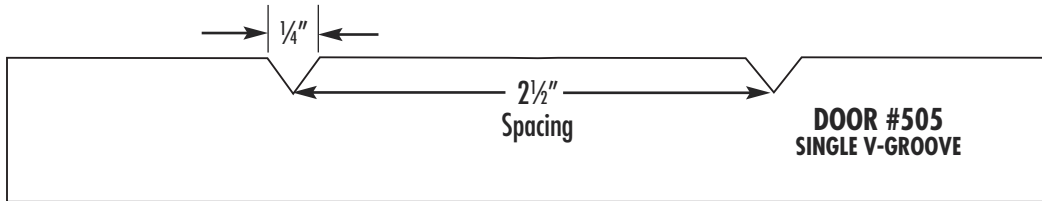

CUSTOM MADE WAINSCOT PANELS

Custom made wainscot panels can be ordered to match almost any door style. Each panel is cut-out and assembled by hand to your exact specifications. Valley Custom Door will guarantee the face of each panel to be free from defect based on the grade of wood selected (see page 5 for details). The backside is typically not guaranteed to be free from defects such as mineral streaks and cross-grain sanding marks. Please submit detailed drawings for production and price quotations.

WAINSCOT PANEL PRICING *Per square foot*

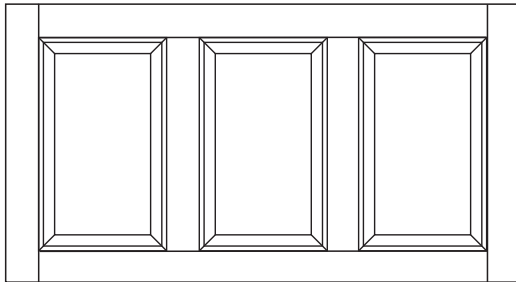

Square Wainscot Panel Available in mitred style also but all frame widths must be the same. Add \$X.XX per sq ft for mitred style panels.

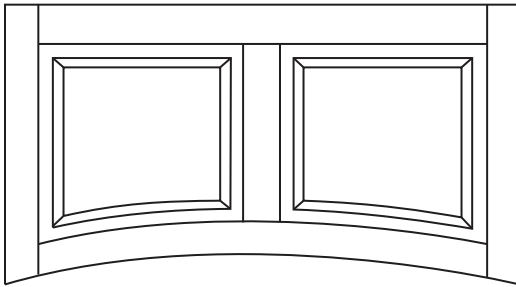

Square w/Radius Bottom Rail
* Add \$XXX.XX for Radius
(Radius must be specified.)

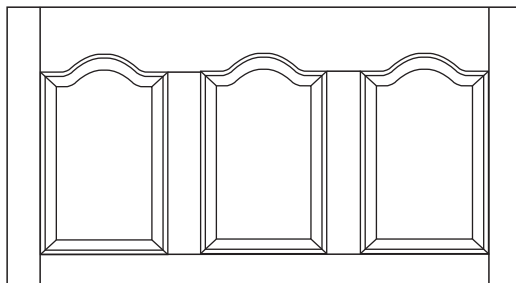

Single Arch Wainscot Panel

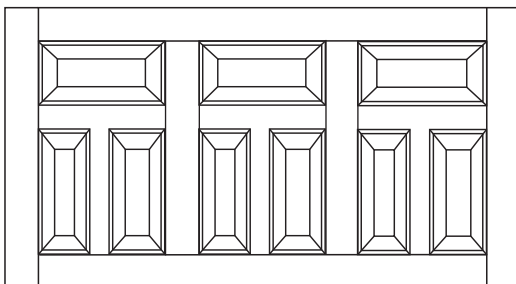

Multi-Panel Wainscot Panel

WOOD SPECIES	RAISED PANEL			1/4" FLAT PANEL		
	SQUARE	SINGLE ARCH	MULTI-PANEL	SQUARE	SINGLE ARCH	MULTI-PANEL
Alder*	X	X	X	X	X	X
Alder Rustic	X	X	X	NA	NA	NA
Ash White	X	X	X	X	X	X
Beech European	X	X	X	NA	NA	NA
Birch Red	X	X	X	NA	NA	NA
Birch Value	X	X	X	X	X	X
Birch White	X	X	X	X	X	X
Butternut	X	X	X	NA	NA	NA
Cedar Knotty	X	X	X	NA	NA	NA
Cherry*	X	X	X	X	X	X
Cherry Rustic	X	X	X	NA	NA	NA
Cherry Value	X	X	X	X	X	X
Hickory*	X	X	X	X	X	X
Hickory Rustic	X	X	X	NA	NA	NA
Lyptus	X	X	X	X	X	X
Mahogany African	X	X	X	NA	NA	NA
Mahogany Genuine	X	X	X	NA	NA	NA
Maple Hard White*	X	X	X	X	X	V
Maple Hard White Value	X	X	X	X	X	X
Maple Hard White Birdseye	X	X	X	NA	NA	NA
Maple White Rustic	X	X	X	NA	NA	NA
Maple Soft	X	X	X	X	X	X
Oak Red*	X	X	X	X	X	X
Oak Red Quarter Sawn	X	X	X	X	X	X
Oak Red Rift	X	X	X	X	X	X
Oak Red Rustic	X	X	X	NA	NA	NA
Oak Red Value	X	X	X	X	X	X
Oak White	X	X	X	X	X	X
Oak White Quarter Sawn	X	X	X	NA	NA	NA
Oak White Rift	X	X	X	NA	NA	NA
Paint Grade*	X	X	X	X	X	X
Paint Grade MDF Panel	X	X	X	X	X	X
Pine White Clear	X	X	X	X	X	X
Pine White Knotty*	X	X	X	X	X	X
Poplar	X	X	X	NA	NA	NA
Walnut	X	X	X	X	X	X

*Available in 5/4 stock add 25%.

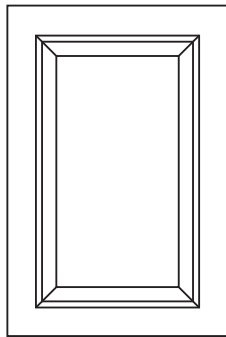

601
8 x 8

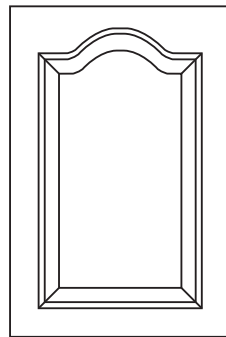

602
8 x 10

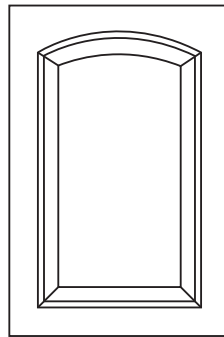

603
8 x 10

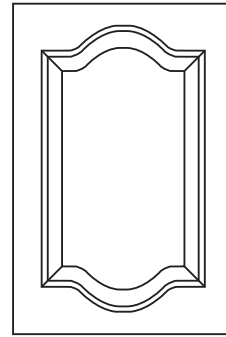

605
8 x 12

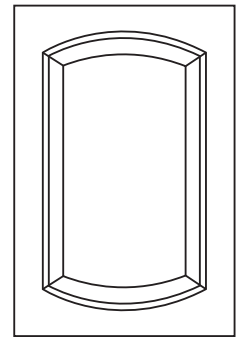

606
8 x 12

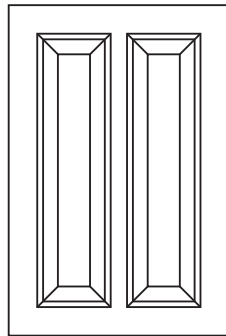

609
13 x 8

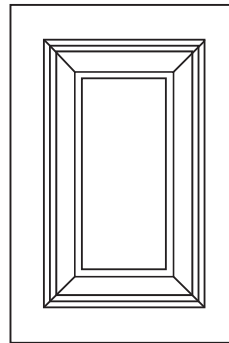

624
8 3/4 x 8 3/4
Will have 3" wide frame



DF-600
8 x 4

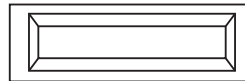

DF-601
8 x 5 1/2

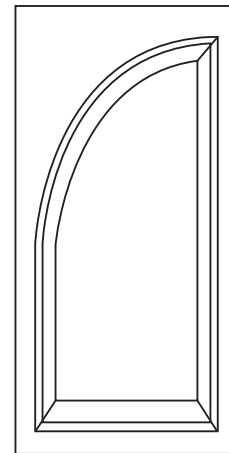

650L
8 x 8

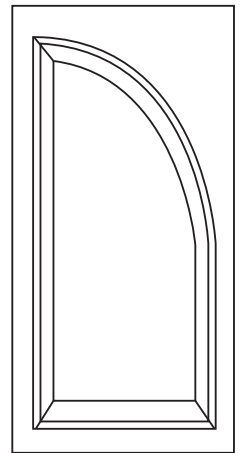

650R
8 x 8

OUTSIDE EDGE PROFILES



E-104



E-105

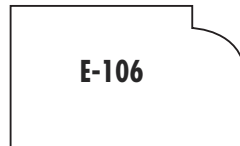

E-106



E-118

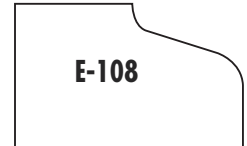

E-108

STILE & RAIL PROFILE

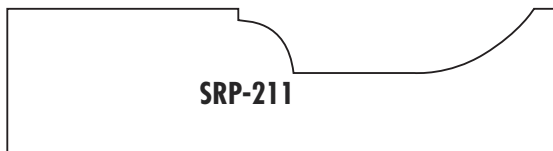

SRP-211

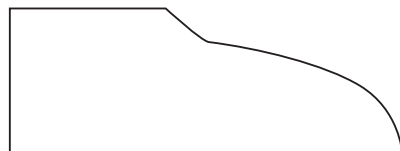

HOW TO PRICE ONE PIECE MDF DOORS

- Multiple Panels: add \$XX.XX per panel. Note: All doors over 48" high will require that at least one center rail be added.
- Wainscot Panels are available, please submit drawings for pricing and availability.
- Door styles 601, 624 and 609 are available with applied moulding using V-102 or SR-107 only. See pages 25 and 27 for information and pricing on applied moulding.

	601	602	603	605	606	609	624	650	DF-600	DF-601
5 pass	X	X	X	X	X	X	X	X	X	X

Note: *One square foot minimum charge will apply on doors.

Note: 1/2 square foot minimum charge on drawer fronts.

35 PREFINISHING

PREFINISHED PRODUCTS:

All stained products are hand-wiped unless otherwise noted and top-coated using a catalyzed conversion varnish with UV inhibitor added to protect against discoloration. All doors and drawer fronts will be placed on hangers for prefinishing. This requires that 2 tiny holes be drilled on the backside for hooks. Unless otherwise specified, these holes will be placed at 3/4" down from the top and bottom of the door.

- We offer two Gloss Finishes: Satin (35-40 sheen) or Matte (15-20 sheen). See chart for availability.
- All Custom Stain or Paint Colors will have a \$XXX.XX set-up charge and will be priced by the square foot. (Price per sq. ft. may vary depending on approved sample.)
- **Please Note: Due to the nature of wood, there will be a certain degree of color grain variation between the color sample and the finished product. These variations are considered natural characteristics of wood and are standard throughout the industry.**
- **We do not recommend painting a solid wood door due to the natural movement that occurs with the environmental conditions of the room which can cause cracking in the paint.**

STAIN FOR PURCHASE	GALLON	QUART	PINT
GROUP 1	X	X	X
GROUP 2	X	X	X
GROUP 3	X	X	X

PAINT FOR PURCHASE	GALLON	QUART	PINT
GROUP 1	X	X	X
GROUP 2	X	X	X
GROUP 3	X	X	X
GROUP 4	X	X	X

ALL GLAZES	GALLON	QUART	PINT
White, Tan, Brown, Black	X	X	X

COMPLETE COLOR SAMPLE BOX \$XXX.XX

Complete set of standard stain, paint and glaze colors shown on solid wood samples.

COLOR SAMPLE CHAIN SET: Each chain set includes all finishes available on each wood species.

HARD MAPLE	OAK
Stained Wiped ColorsX	Stained X
Stained No-Wipe Colors . . .X	
Glazed Wiped ColorsX	CHERRY
Glazed No-Wipe Colors . . .X	Stained X
	Glazed X
ALDER	PAINTED
StainedX	Paint X
GlazedX	Glazed X

NOTE: No wipe finishes are not recommended on doors or drawer fronts using profiles SR-30, SR-30FP, SR-30G, SR-40, SR-40G, MR-30, MR-40, MR-365, DF-365, MR-367 and DF-367.

CUSTOMIZED FINISHES: We strongly recommend that a sample door is ordered for customer approval for any customized finish.

Glazing Hand Wiped: Available on STAINED or PAINTED finishes. This technique has the glaze applied to the entire surface on the face side then wiped off with a cloth leaving a thin coating over the flat surface while leaving heavier glaze coverage in and on profiles and corners.

See page 36 for pricing and availability on Standard Finishes.

Glazing Brushed: Available on PAINTED finishes only. This technique has the glaze applied to the surface on the face side then it is brushed leaving a very light, even coating of glaze on all surfaces.

See page 36 for pricing and availability on Standard Finishes.

Heirloom Finish: This is a rubbed through process available on a STAINED or PAINTED finish. The corners and profiles are randomly sanded down to reveal the natural wood beneath and then top-coated with our catalyzed conversion varnish. A sample door must be ordered with each job for customer approval. **COST \$X.XX sq ft**

Vintage Finish: This is rubbed through process available on any STAINED finish. The door is stained first then a black overcoat is applied to the entire surface and rubbed off randomly to reveal the stained surface beneath. The catalyzed conversion varnish top-coat is applied last. A sample door must be ordered with each job for customer approval. **COST \$X.XX sq ft**

Vintage Finish: This is rubbed through process available on any STAINED finish. The door is stained first then a black overcoat is applied to the entire surface and rubbed off randomly to reveal the stained surface beneath. The catalyzed conversion varnish top-coat is applied last. A sample door must be ordered with each job for customer approval. **COST \$X.XX sq ft**

Flow Pen: A flow pen is filled with glaze material and used to draw a line around the profiles of a door or drawer front to make them stand out. Flow Pen colors are available in Brown, Black and White. **COST \$X.XX sq ft**

Distressed Finish: (Available on solid wood only) We recommend that a sample door is ordered for each job.

Light: Using a distressing tool, there will be random placement of nicks on the faces only. **COST \$X.XX sq ft**

Heavy: Using a distressing tool, there will be random placement of nicks and worm holes with the edges and corners sanded down to resemble wear marks. **COST \$X.XX sq ft**

All pricing is per square foot. 1 square foot minimum on doors • 1/2 square foot minimum on drawer fronts

STAIN COLOR / GROUP	HARD MAPLE					CHERRY				ALDER			OAK Stained Only
	Stained Only	STAINED & GLAZED				Stained Only	STAINED & GLAZED			Stained Only	STAINED & GLAZED		
		White Glaze	Tan Glaze	Brown Glaze	Black Glaze		White Glaze	Brown Glaze	Black Glaze		Brown Glaze	Black Glaze	
Aspen White (2)	X			X	X								X
Autumn Wheat (3)	X	X		X	X	X	X	X		X			X
Banister Oak (3)													X
Bordeaux (1)	X				X	X							
Brandy (2)						X			X				X
Carmel (3)	X	X		X	X					X			X
Chestnut (3)						X			X	X			X
Coffee* (2)													X
Dark Pecan* (2)						X				X			X
Dixie Mahogany* (1)	X												
Fawn (3)	X	X		X	X								
Grand Cherry (2)	X												
Harvest (2)	X									X	X	X	
Honey Maple (3)	X	X		X	X					X			
Mocha* (2)													X
Natural (-)	X			X	X	X		X	X	X	X	X	X
Regal Cherry (3)						X			X	X			
Wild Cherry (3)						X		X					
Windsor Mahogany* (1)	X									X			
CUSTOM STAIN++ (1)	X					X				X			X
Spray-on/No Wipe Stain													
Briar Mist (2)	X	X		X									
Buttermilk (2)	X			X									
Dark Honey (2)	X			X									
Golden Tone (2)	X			X									
Light Nutmeg (2)													
Mirage* (2)	X			X									
Natural Pear (2)	X	X		X									

*Available with Satin Finish ONLY • **Available with Matte Finish ONLY ++Custom Stain or Paint charges may vary pending receipt and approval of color sample.

PAINT COLOR / GROUP	PAINTED & GLAZED					
	Painted Only	Hand Wiped Brown	Brushed Brown	Hand Wiped Black	Brushed Black	Hand Wiped Tan
Basil (3)	X			X	X	
Champagne (1)	X					X
Ebony (2)	X					
Eggshell (4)	X	X	X	X	X	
Iceland (3)	X			X	X	
Ivory (4)	X					
Sage (3)	X	X	X			
Sand (3)	X	X	X			
Snow White (4)	X	X	X			
Washington Cherry (2)	X			X	X	
Custom Paint++ (2)	X					

DOVETAILED DRAWER BOXES

Our standard drawer box material is 5/8" thick. Please note that unless you specify another wood type on your order for drawer boxes, we will use STANDARD GRADE MAPLE for the sides. This will be a random selection of off-color Maple.

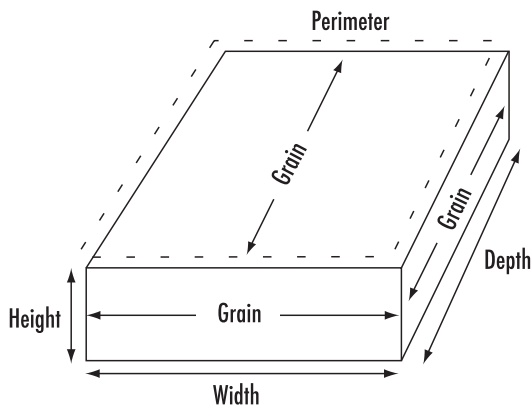

To figure the cost for each drawer box, follow this procedure:

1. Measure the perimeter of the box, rounding up to the next full inch.
2. Add all four of the dimensions together, then using the pricing chart below, find the drawer box height and the proper wood type to determine the cost per inch.
3. Multiply the total number of inches by the corresponding cost.
4. Add cost of bottom panel priced below per square foot.
5. Repeat this procedure for each drawer box, and add any additional upcharges such as assembly, prefinish, etc.

	STANDARD GRADE Not selected for color				SELECT GRADE							
HEIGHT	Maple	Red Oak	Cherry	9 Ply Birch	Red Oak	Hard Maple	Cherry	Clear Pine	Hickory	White Oak	Walnut	White Ash
4" less	X	X	X	X	X	X	X	X	X	X	X	X
4-1/16" - 6"	X	X	X	X	X	X	X	X	X	X	X	X
6-1/16" - 8"	X	X	X	X	X	X	X	X	X	X	X	X
8-1/16" - 10"	X	X	X	X	X	X	X	X	X	X	X	X
10-1/16" - 12"	X	X	X	X	X	X	X	X	X	X	X	X
12-1/16" - 14"	X	X	X	X	X	X	X	X	X	X	X	X

	PLYWOOD BOTTOMS PRICED PER SQ. FT.			
	1/4"	1/4" GRADE	1/2"	1/2" GRADE
Maple (Standard Grade)	X	C-4	NA	-
Birch	X	B-4	X	D-2
Red Oak	X	A-4	X	A-1
Hard Maple	X	A-4	X	A-2
Cherry	X	A-4	X	A-2
Clear Pine	X	A-1	NA	-
Hickory	X	A-1	X	A-2
White Oak	X	A-1	NA	-
Walnut	X	A-1	NA	-
White Ash	X	A-1	NA	-
Hardboard	X	-	NA	-
White Melamine	X	-	X	-

DRAWER BOX MINIMUM SIZE:

Width 4 1/2"
Depth 5"
Height 2"

DRAWER BOX MAXIMUM SIZE:

Width 48"
Depth 48"
Height 14"

*STANDARD DRAWER BOX DEPTHS: 21" • 18"

*Please use our standard depths whenever possible.

OPTIONS

- **Assembly of Drawer Box: \$X.XX each box.**
All drawer boxes will be sanded and ready to finish.
- **Prefinishing of Drawer Box: \$X.XX each box.**
All drawer boxes will be prefinished with 2 coats of catalyzed varnish. **Add \$X.XX per box if melamine bottoms are used.**

BOTTOM PANEL ASSEMBLY OPTIONS

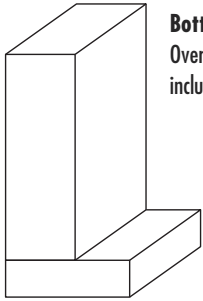

Bottom Mount
Overall box height does NOT include bottom panel.

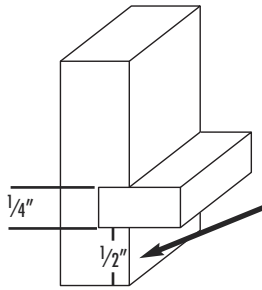

Inset Mount
Standard groove is made at 1/2" up from the bottom, unless otherwise specified.

CORNER DRAWER

ADD \$XX.XX PER BOX WITHOUT OPTIONAL BACK PORTION

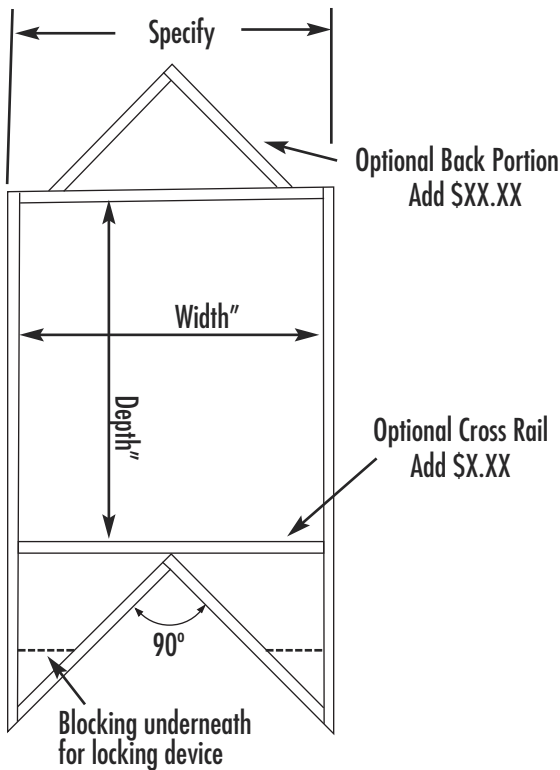

NOTCHING FOR UNDERMOUNT DRAWER TRACKS

Rear view of drawer notch and bore details.

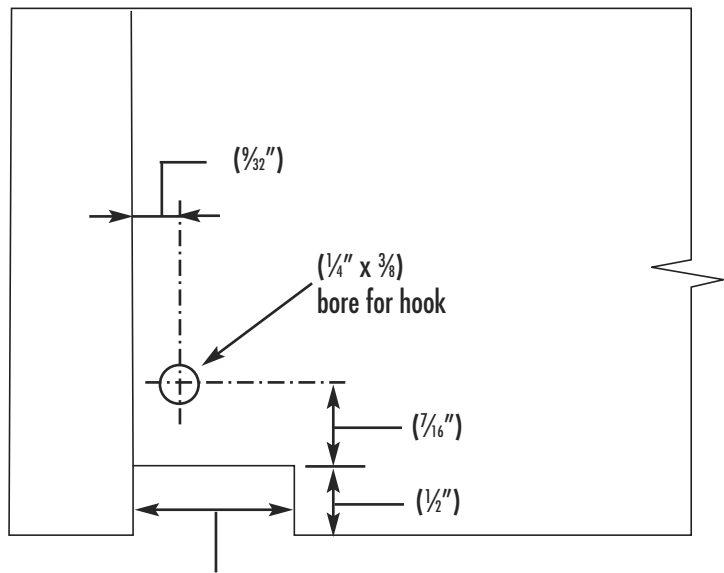

Width of Notch	1" - 2"	2" - 4" +
Price	X	X

DRAWER GUIDES	LENGTH	COST Per Pair
BLUM™ Tandem Full Extension		
562 Series with Locking Device	12"	X
	15"	X
	18"	X
	21"	X
BLUM™ Motion Full Extension	9"	X
562 Series with Locking Device	12"	X
	15"	X
	18"	X
	21"	X
BLUM™ Rear Mount Kit		X
BLUM™ Top Mount Kit		X
FULL Extension Side Mount	12"	X
Hettich Brand #KA5632	14"	X
	16"	X
	18"	X
	20"	X
	22"	X
FULL Extension Rear Mount Bracket		X

39 DOVETAIL DRAWER OPTIONS

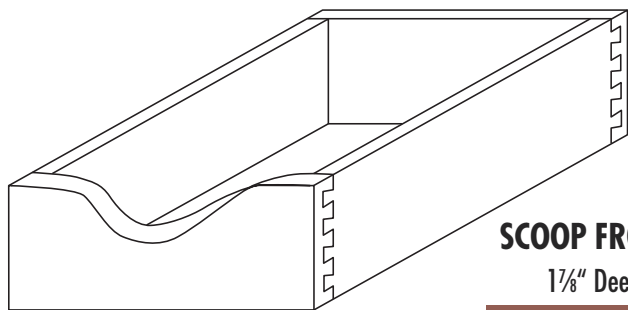

SCOOP FRONTS

1 7/8" Deep

ADD \$X.XX PER BOX

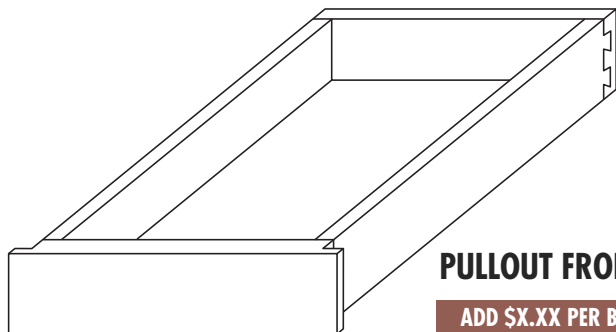

PULLOUT FRONTS

ADD \$X.XX PER BOX

Pullouts come standard with 7/16" extended front to cover drawer tracks.
NOTE: We will add the 7/16" to the drawer box size you give us.

HIGHBACK (HB-1)

ADD \$X.XX PER BOX
ADD \$X.XX FOR SCOOP

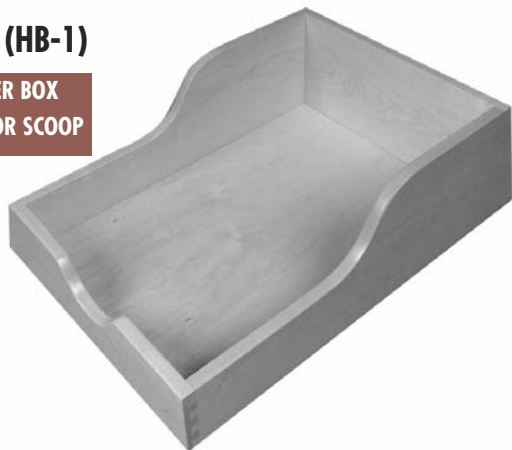

SPICE TRAY INSERT

ITEM #ST-1
16" WIDE - \$XX.XX EACH
22" WIDE - \$XX.XX EACH

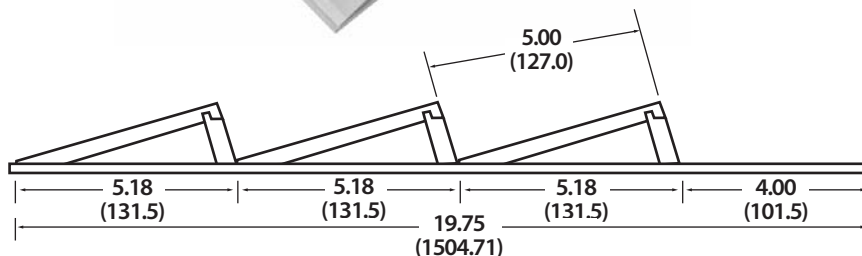
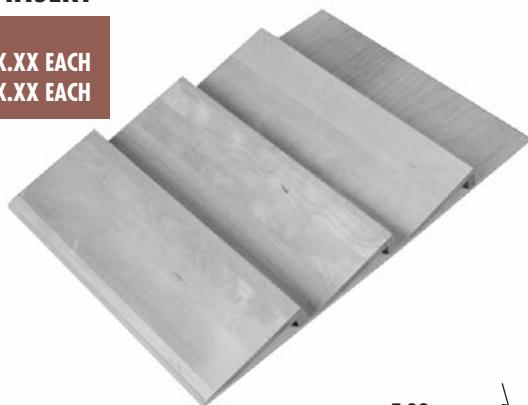

WOOD KNIFE BLOCK INSERT

*Does not include price of drawer box.

Maximum 18 1/2" wide with 19 slots. Can be ordered with optional cork insert.

ITEM - #KB-1 - \$XX.XX EACH
CORK INSERT - \$X.XX SQ FT

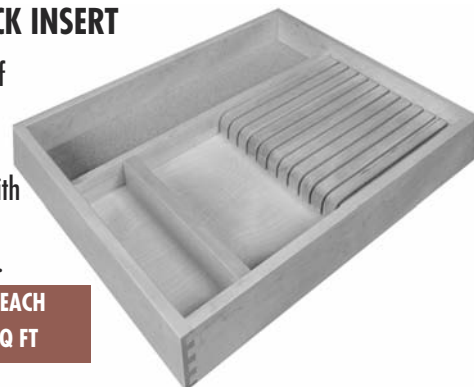

FILE HANGERS

ITEM #HF-1 - \$X.XX EACH

*Does not include price of drawer box.



Minimum Inside Height 9 1/2"
Minimum Inside Width: 13"

DRAWER PEG SYSTEM

ITEM #PB-1
\$XX.XX PER SQ FOOT - MINIMUM 3 SQ FT CHARGE

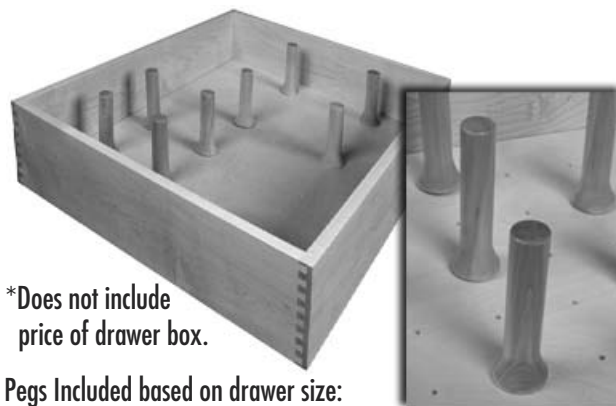

*Does not include price of drawer box.

Pegs Included based on drawer size:
4 sq ft = 9 pegs
5 sq ft = 12 pegs
6 sq ft = 16 pegs

Additional Pegs Available
(4/per pack)
COST: \$X.XX PER PACK

9" - 13" WIDE

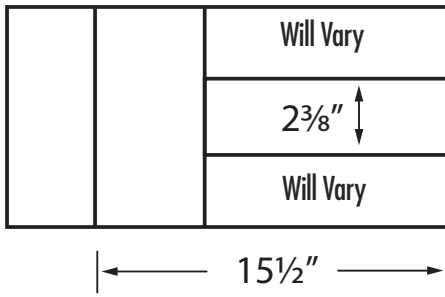

OPTIONAL SILVERWARE INSERT

Custom made 1/2" dividers with configurations based on width of drawer box, as shown below. Standard width of 2 3/8" will be used for interior openings unless otherwise specified.

DD-2 SILVERWARE TRAY INSERT: COST \$XX.XX SQ FT

**SLIDING DRAWER WITHIN A DRAWER
(SHOWN WITH OPTIONAL DD-2 SILVERWARE TRAY)**



To price as shown figure:

- the cost of the bottom box (pg 37)
 - the cost of the top box (pg 37)
 - add \$XX.XX / sq ft for the Optional Silverware Tray
 - add \$XX.XX for Full Extension Drawer Tracks and assembly
- Shipped fully assembled.

**UTILITY DRAWER
STYLE: DD-1**

Openings will vary in width based on width of drawer box.

COST : \$XX.XX SQ FT

13" - 16" WIDE

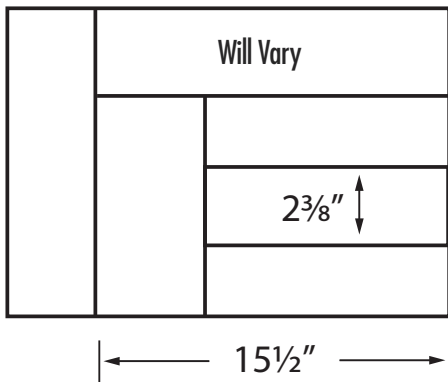

16" - 19" WIDE

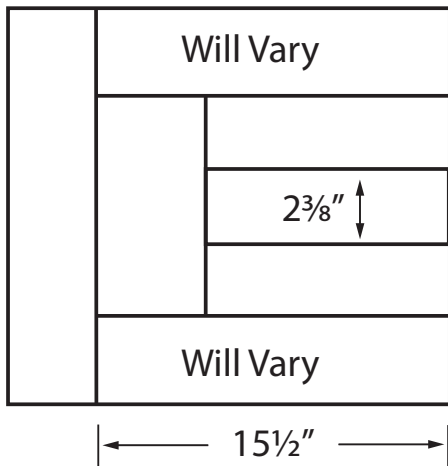

19" - 24" WIDE

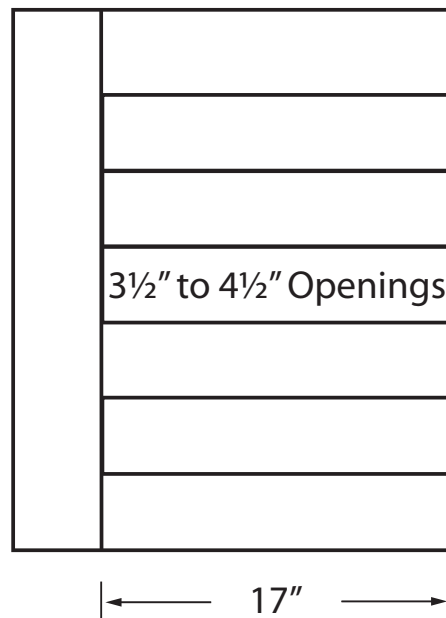
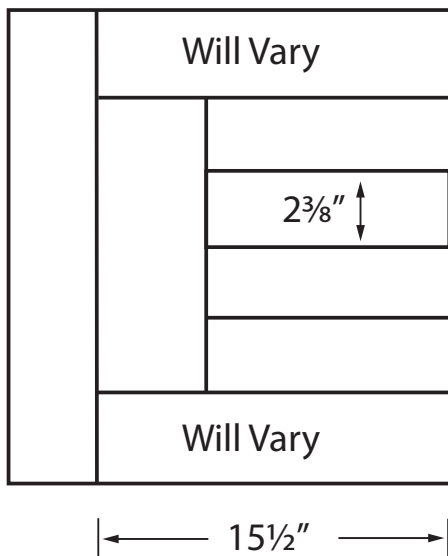

41 OPTIONS

ROUTED FINGER PULL

Finger pulls can be routed on the backsides of doors and drawer fronts. The location must be clearly marked.

COST: \$X.XX PER DOOR

Please use the abbreviations listed to indicate where you would like the finger pull placed.

Finger Pull

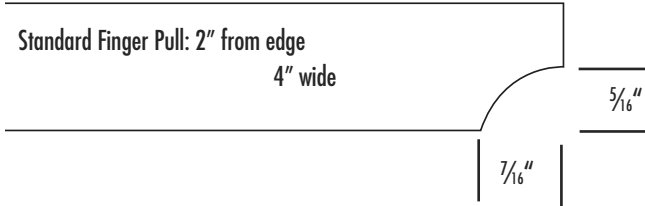

Finger pulls will only work with the following outside edge profiles: E-101, E-104, E-105, E-106, E-110, E-114, E-115, E-117, E-118, E-121, E-122, E-123, E-124, E-126, E-127

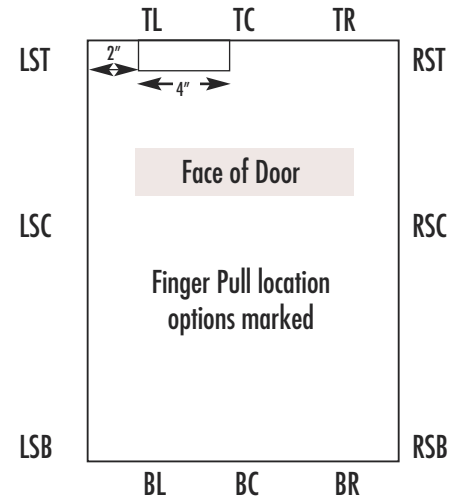

RADIUS CORNERS

You can add a radius to the outside edge of doors and drawer fronts. The following edges E-104, E-105, E-106, E-108, E-118, E-121, E-123, E-124, and E-126 are available with a 1/4", 1/2", or 1" radius.

COST: \$X.XX PER DOOR

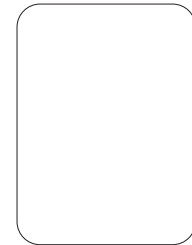

HALF LAP EDGE

Half lap edges can be ordered on any door style or door edge. This is used on pairs of doors that meet in the center. The door on the right will open first unless otherwise noted. The left rail will be 3/8" wider than the right so the door stiles are the same width on face. (See Sketch)

COST: \$XX.XX PER DOOR

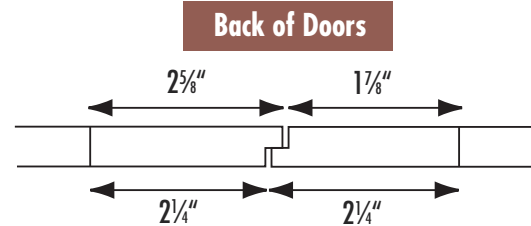

Face of Doors

Example of Half Lap

VENEERED BREAD BOARD

Each bread board is 21 3/4" deep with one solid Oak end and one solid Maple end. There are 1-1/2" solid wood rails on each side that will allow the board to be trimmed to your specified width.

COST:

16" Wide	24" Wide
X	X

WINE RACK LATTICE

Wine Rack Lattice is in stock in Red Oak, Hard Maple, Cherry or Hickory. The lattice itself is 3/4" x 3/4" thick and the frame is also 3/4" thick. Prices per square foot include the 2-piece (front and back) framed wine rack.

• Minimum Size is 7 1/2" x 7 1/2" • Openings are 4" x 4"

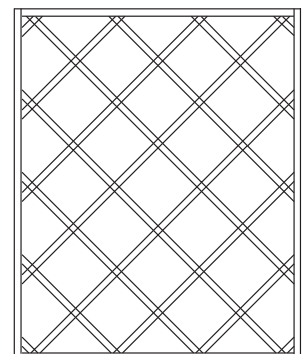

UNFINISHED price per square foot

Red Oak	Hard Maple	Cherry	Hickory
X	X	X	X

PREFINISHED price per square foot

Red Oak	Hard Maple	Cherry	Hickory
X	X	X	X

BUTT DOORS

Butt doors can be ordered on any door style with an outside edge profile. Typically this is used when a pair of doors needs to have one long edge square where they butt together. Please specify Butt left or Butt right on all arched doors. (See sketch.)

COST: \$X.XX PER DOOR

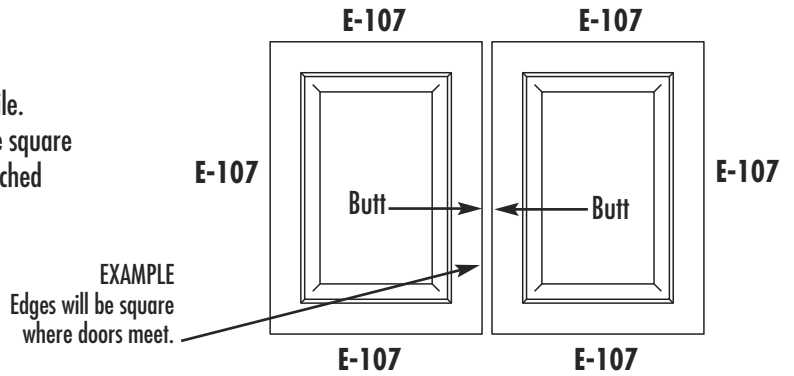

LAZY SUSAN DOORS OR CORNER DOORS (For Cope & Stick doors only)

One option for these types of doors is to use a 45° mitred corner joint. Each door will have one 3" stile that when mitred together gives the appearance of 2 1/4" stiles to match the rest of the door. This style will allow you to use a piano hinge or a pie cut hinge. (See sketch.) **Order exact door size needed and note 45° Miter Joint Pair.**

Another option is to order one door with one 3" stile on the butt side and a 2 1/4" stile on the other door. This will give the illusion of both stiles being 2 1/4" wide. Standard hinges can be used on these doors. (See sketch.) **Order exact door size needed and note + 3/4 Butt Joint Pair.**

COST: 45° MITRE - \$X.XX EACH DOOR INCLUDES 3" STILE AND 45° MITRE BUTT JOINT - \$X.XX INCLUDES 3" STILE AND BUTT EDGE

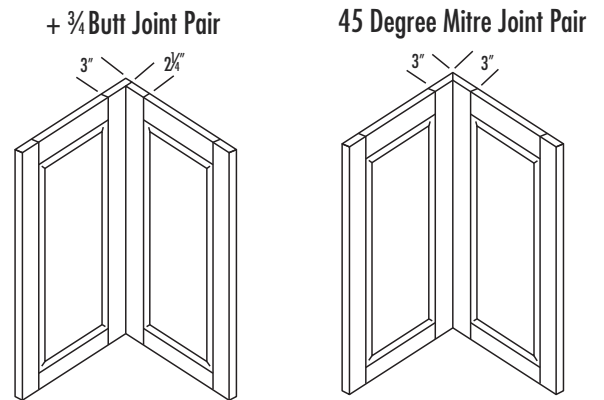

LAZY SUSANS BY REV-A SHELF®

Made of Maple using a 5/8" thick high-density multi-ply tray and 1" high solid wood rim that's protected with a UV-cured clear coat finish. Pre-assembled with swivel bearing and stop included.

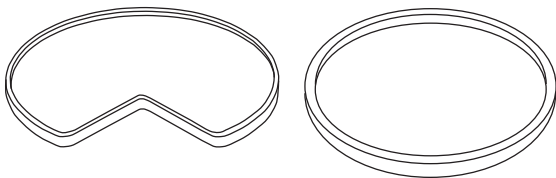

Size	Description	Price
28"	Kidney Shaped with swivel and stop	X
32"	Kidney Shaped with swivel and stop	X
28"	Full Circle with swivel and stop	X

TOP MOUNT PULL-OUT WASTE CONTAINERS BY REV-A-SHELF®

Made from solid wood construction, these Top Mount Pull-Out Waste Containers are available in a single and double 35 quart variety. Designed for absolute sturdiness with front side mounting, rear adjustable mounting brackets for variances in cabinet depth, pre-assembled door mounting brackets and full-extension 150 lbs. rated over-travel slides. 35 quart polymer bins are included. The single also includes a short polymer bin that provides an extra storage space for garbage bags.

Opening	Description	Price
12"	Single 35 Qt Container (w/extra storage bin)	X
15"	Double 35 Qt Container	X
18"	Double 35 Qt Container	X

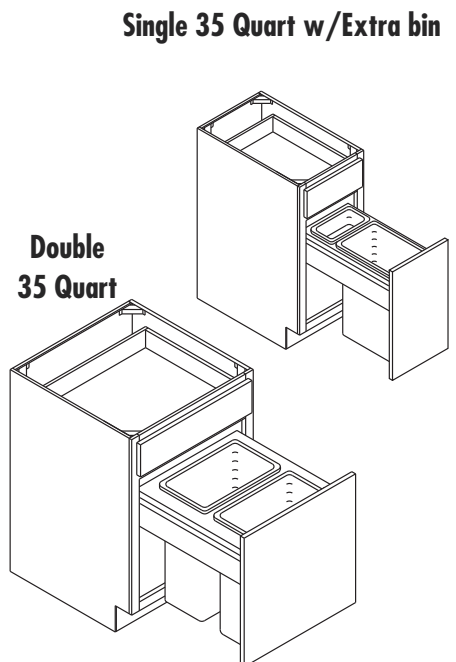

43 VALANCES & SHELVES

VALANCE & SHELF PRICING PER SQUARE FOOT

Note: *Prefinish Cost is charged per square foot as listed per color on page 34.

All valances have a 4" minimum height unless otherwise specified.

WOOD SPECIES	VALANCE STYLES						
	A	B	C	D	F	G	ALL Shelves
Alder*	X	X	X	X	X	X	X
Alder Rustic	X	X	X	X	X	X	X
Ash White	X	X	X	X	X	X	X
Beech European	X	X	X	X	X	X	X
Birch Red	X	X	X	X	X	X	X
Birch White	X	X	X	X	X	X	X
Butternut	X	X	X	X	X	X	X
Cedar Knotty	X	X	X	X	X	X	X
Cherry*	X	X	X	X	X	X	X
Cherry Rustic	X	X	X	X	X	X	X
Hickory*	X	X	X	X	X	X	X
Hickory Rustic	X	X	X	X	X	X	X
Lyptus	X	X	X	X	X	X	X
Mahogany African	X	X	X	X	X	X	X
Mahogany Genuine	X	X	X	X	X	X	X
Maple Hard White*	X	X	X	X	X	X	X
Maple Hard White Birdseye	X	X	X	X	X	X	X
Maple Rustic White	X	X	X	X	X	X	X
Maple Soft	X	X	X	X	X	X	X
Oak Red*	X	X	X	X	X	X	X
Oak Red Quarter Sawn	X	X	X	X	X	X	X
Oak Red Rift	X	X	X	X	X	X	X
Oak White	X	X	X	X	X	X	X
Oak White Quarter Sawn	X	X	X	X	X	X	X
Oak White Rift	X	X	X	X	X	X	X
Paint Grade*	X	X	X	X	X	X	X
Pine White Clear	X	X	X	X	X	X	X
Pine White Knotty*	X	X	X	X	X	X	X
Poplar	X	X	X	X	X	X	X
Walnut	X	X	X	X	X	X	X

SHELVES

All shelves are shown as a top view.

Customer must specify this radius

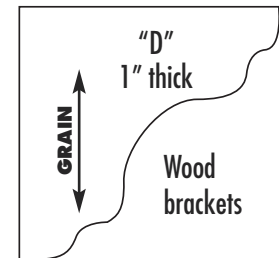
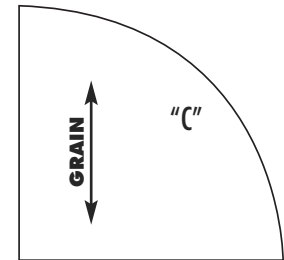
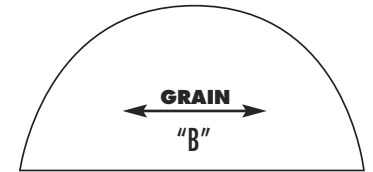
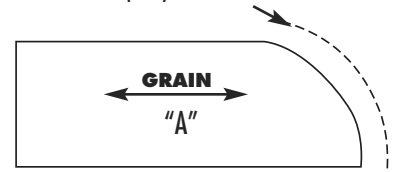

VALANCES

All valances will have square edges (E-104) on all 4 sides as standard unless otherwise specified.

Add \$X.XX each for any other edge.

Scalloped valances can only be edged on the scalloped edge using: E-101, E-105, E-106, E-108, E-110, E-115, E-118, or E-121. Add \$XX.XX each.

*Available in 5/4 stock add 25%.

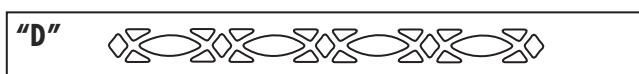
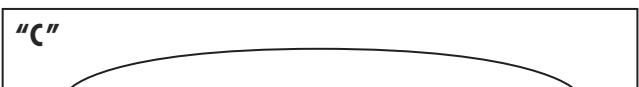

"D" Minimum height is 5"

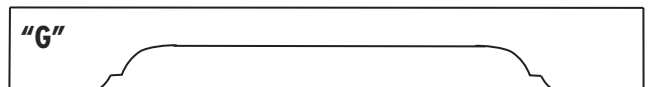
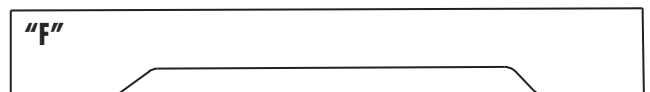

"H" Minimum height is 7-1/4" and will be priced like a door based on style selected.

Appliance Panels shown are for a dishwasher application.

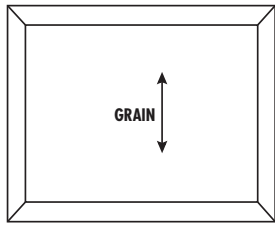

STYLE "A"

Solid raised panel only with your choice of panel profiles: P-201, P-202, P-203, P-207, P-209, P-211 and P-217.

1/4" plywood back is not needed with this style.

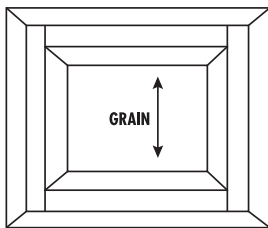
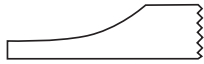
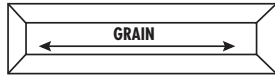

STYLE "B"

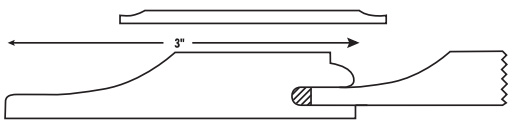

Top panel is standard 5-piece construction with a 3" frame. Bottom panel is a slab style with P-201 outside edge. 1/4" plywood back is not needed with this style.

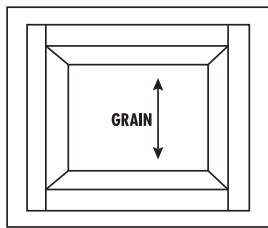

STYLE "C"

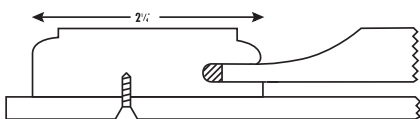
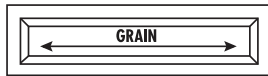

Top panel is standard 5-piece door construction. Bottom panel is a slab style with a routed edge.

*1/4" plywood back must be ordered separately. See page 63 for pricing.

APPLIANCE PANEL PRICING

Note: One square foot minimum charge will apply.

WOOD SPECIES	Style A	Style B	Style C
Alder	X	X	X
Alder Rustic	X	X	X
Ash White	X	X	X
Beech European	X	X	X
Birch Red	X	X	X
Birch White	X	X	X
Butternut	X	X	X
Cedar Knotty	X	X	X
Cherry	X	X	X
Cherry Rustic	X	X	X
Hickory	X	X	X
Hickory Rustic	X	X	X
Lyptus	X	X	X
Mahogany African	X	X	X
Mahogany Genuine	X	X	X
Maple Hard White	X	X	X
Maple Hard White Birdseye	X	X	X
Maple Rustic White	X	X	X
Maple Soft	X	X	X
Oak Red	X	X	X
Oak Red Quarter Sawn	X	X	X
Oak Red Rift	X	X	X
Oak White	X	X	X
Oak White Quarter Sawn	X	X	X
Oak White	X	X	X
Paint Grade	X	X	X
Pine White Clear	X	X	X
Pine White Knotty	X	X	X
Poplar	X	X	X
Walnut	X	X	X

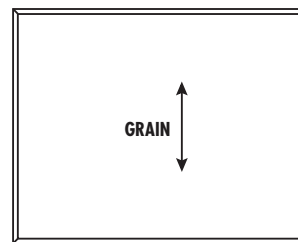

STYLE "D"

*1/4" Plywood Panels only. See page 63 for pricing.

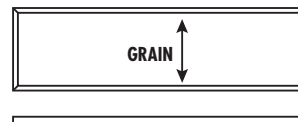

45 HINGE BORING

HINGE BORING

Standard diameter of bore is 35mm wide with a depth of 1/2". Standard boring locations are shown below. Please check the **Concealed Hinge Boring Chart** to determine which edges can be used with concealed hinges.

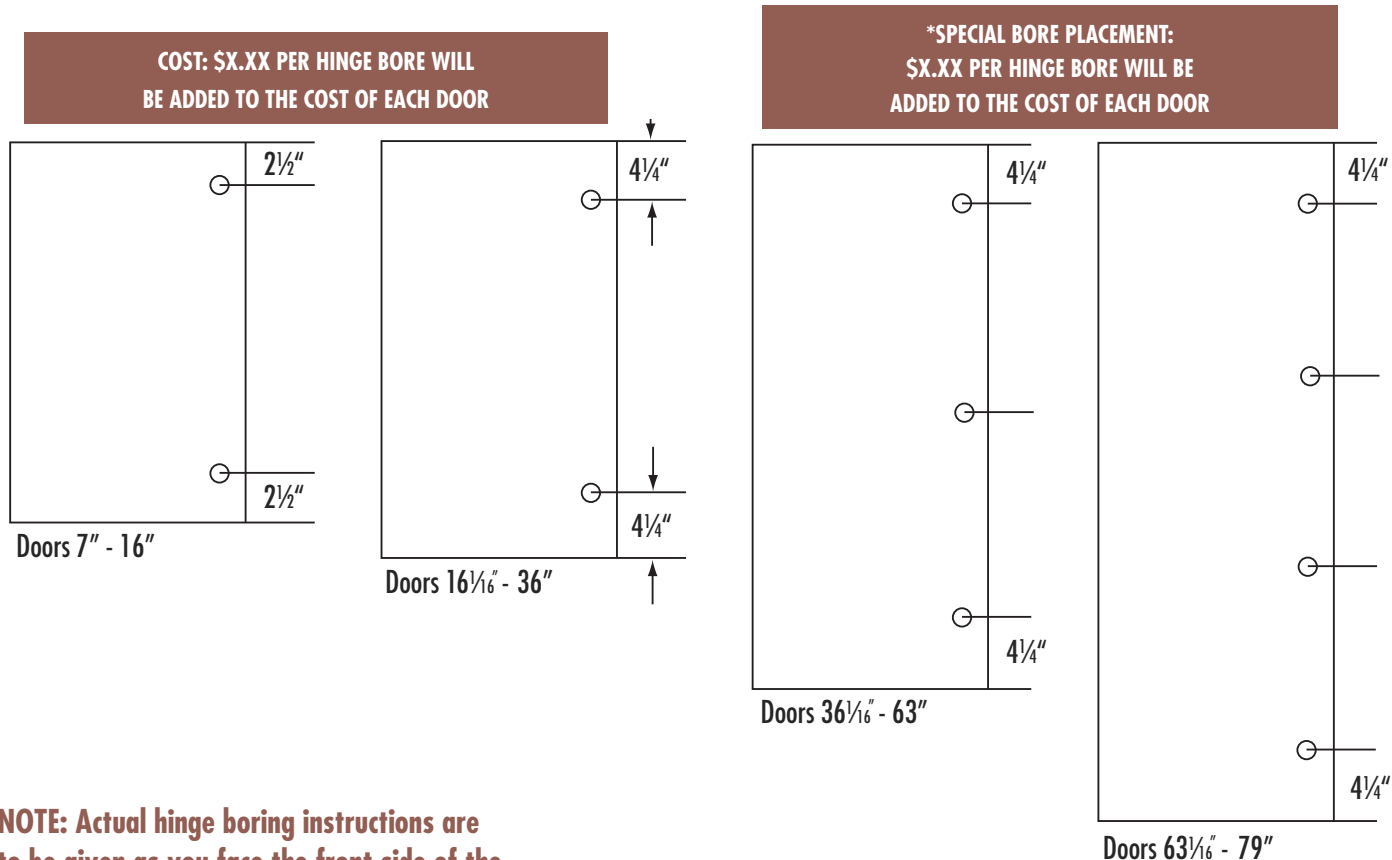

NOTE: Actual hinge boring instructions are to be given as you face the front side of the door. These sketches show the hinge bore on the backside of the door and are actually "hinged left" for ordering purposes.

*Special Bore Placement charges will apply for any hinge bore placement that is not consistent with the majority of bore placements on the order.

We stock Hettich™ brand hinges which are a high quality hinge offering 6-way adjustment features. Choose 110° opening hinges in 1/4", 1/2" and 3/4" overlays or 176° opening hinges in 1/2" or 3/4" overlay. (5/8" screws are included)

Opening	1/4" Overlay	1/2" Overlay	3/4" Overlay
110°	\$X.XX/pair	\$X.XX/pair	\$X.XX/pair
176°	NA	\$X.XX/pair	\$X.XX/pair

Concealed Hinge Boring Chart

Outside Edge		Distance in from the edge of the door:			
		2.5mm 3/32	3.2mm 1/8	4mm 5/32	4.8mm 3/16
E-101	1/2" cup depth	YES	YES	YES	YES
	7/16" cup depth	YES	YES	YES	YES
E-102	1/2" cup depth	This edge is drilled at 9/32" ONLY allowing for 5/8" overlay			
	7/16" cup depth				
E-103	1/2" cup depth	NO	NO	NO	NO
	7/16" cup depth	NO	NO	NO	NO
E-104	1/2" cup depth	YES	YES	YES	YES
	7/16" cup depth	YES	YES	YES	YES
E-105	1/2" cup depth	YES	YES	YES	YES
	7/16" cup depth	YES	YES	YES	YES
E-106	1/2" cup depth	YES	YES	YES	YES
	7/16" cup depth	YES	YES	YES	YES
E-107	1/2" cup depth	NO	NO	NO	NO
	7/16" cup depth	NO	NO	NO	NO
E-108	1/2" cup depth	NO	NO	NO	NO
	7/16" cup depth	NO	NO	YES	YES
E-109	1/2" cup depth	NO	NO	NO	NO
	7/16" cup depth	YES	YES	YES	YES
E-110	1/2" cup depth	YES	YES	YES	YES
	7/16" cup depth	YES	YES	YES	YES
E-111	1/2" cup depth	NO	NO	NO	YES
	7/16" cup depth	NO	YES	YES	YES
E-112	1/2" cup depth	NO	NO	NO	NO
	7/16" cup depth	NO	YES	YES	YES
E-113	1/2" cup depth	NO	NO	NO	NO
	7/16" cup depth	NO	NO	NO	NO
E-114	1/2" cup depth	YES	YES	YES	YES
	7/16" cup depth	YES	YES	YES	YES
E-115	1/2" cup depth	YES	YES	YES	YES
	7/16" cup depth	YES	YES	YES	YES
E-116	1/2" cup depth	NO	NO	NO	NO
	7/16" cup depth	NO	NO	NO	NO
E-117	1/2" cup depth	NO	NO	YES	YES
	7/16" cup depth	YES	YES	YES	YES
E-118	1/2" cup depth	NO	NO	YES	YES
	7/16" cup depth	YES	YES	YES	YES
E-121	1/2" cup depth	YES	YES	YES	YES
	7/16" cup depth	YES	YES	YES	YES
E-122	1/2" cup depth	YES	YES	YES	YES
	7/16" cup depth	YES	YES	YES	YES
E-123	1/2" cup depth	YES	YES	YES	YES
	7/16" cup depth	YES	YES	YES	YES
E-124	1/2" cup depth	YES	YES	YES	YES
	7/16" cup depth	YES	YES	YES	YES
E-126	1/2" cup depth	NO	NO	NO	NO
	7/16" cup depth	YES	YES	YES	YES
E-127	1/2" cup depth	NO	YES	YES	YES
	7/16" cup depth	YES	YES	YES	YES
E-129	1/2" cup depth	NO	NO	NO	NO
	7/16" cup depth	YES	YES	YES	YES
E-130	1/2" cup depth	NO	YES	YES	YES
	7/16" cup depth	YES	YES	YES	YES

Distance in from the edge of the door:

Outside Edge		2.5mm	3.2mm	4mm	4.8mm
		3/32	1/8	5/32	3/16
MR-360	1/2" cup depth	NO	NO	YES	YES
	7/16" cup depth	YES	YES	YES	YES
MR-362	1/2" cup depth	YES	YES	YES	YES
	7/16" cup depth	YES	YES	YES	YES
MR-363	1/2" cup depth	YES	YES	YES	YES
	7/16" cup depth	YES	YES	YES	YES
MR-364	1/2" cup depth	YES	YES	YES	YES
	7/16" cup depth	YES	YES	YES	YES
MR-365	1/2" cup depth	YES	YES	YES	YES
	7/16" cup depth	YES	YES	YES	YES
MR-366	1/2" cup depth	YES	YES	YES	YES
	7/16" cup depth	YES	YES	YES	YES
MR-369	1/2" cup depth	YES	YES	YES	YES
	7/16" cup depth	YES	YES	YES	YES
MR-370	1/2" cup depth	YES	YES	YES	YES
	7/16" cup depth	YES	YES	YES	YES
MR-371	1/2" cup depth	NO	YES	YES	YES
	7/16" cup depth	YES	YES	YES	YES
MR-372	1/2" cup depth	YES	YES	YES	YES
	7/16" cup depth	YES	YES	YES	YES
MR-373	1/2" cup depth	YES	YES	YES	YES
	7/16" cup depth	YES	YES	YES	YES

Our hinge bore is for a standard 35mm cup, 1/2" deep
Please note that not all outside edge profiles will work
with concealed hinges.

Sketches Are NOT Drawn To Scale.

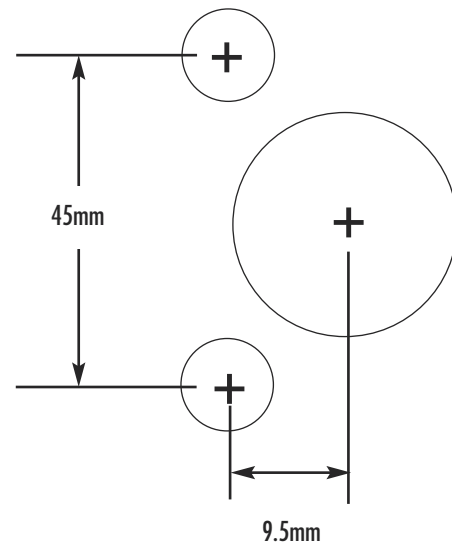

Hinge Bore Pattern #HBP 100

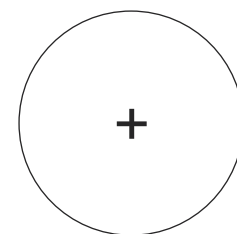

Hinge Bore Pattern #HBP 300

HINGE BORING PATTERNS

HBP 100 One 35mm bore with two 8mm dowel holes per sketch (fits most Blum hinges).

HBP 300 One 35mm bore, no dowel holes.

When ordering hinge boring, please specify which pattern you would like and the drilling distance in from the edge of the door. (See Concealed Hinge Boring Chart).

47 CUSTOM WOOD HOODS

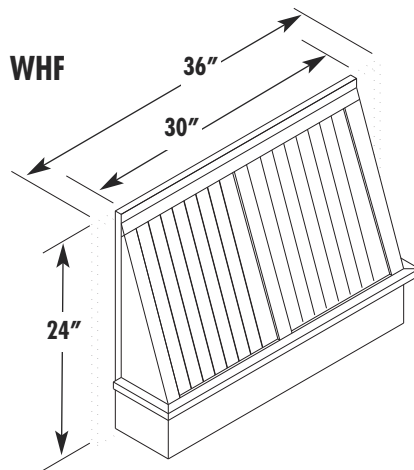
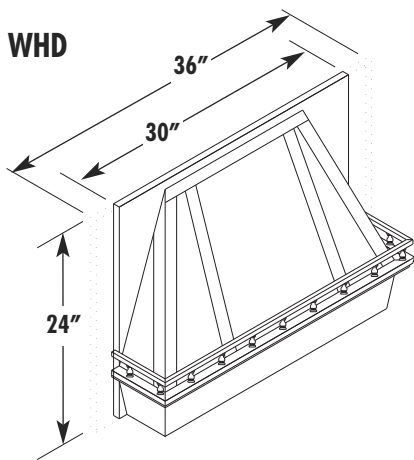
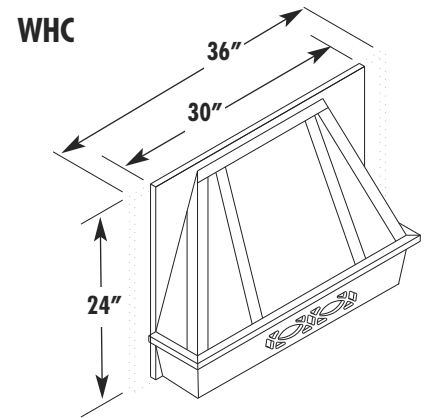
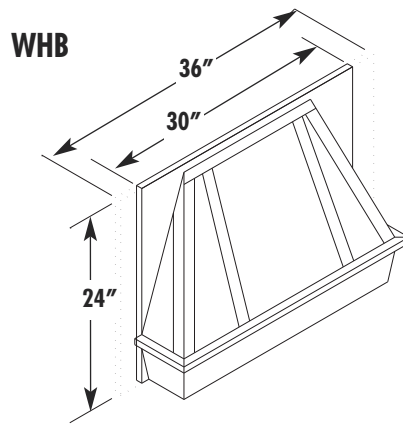
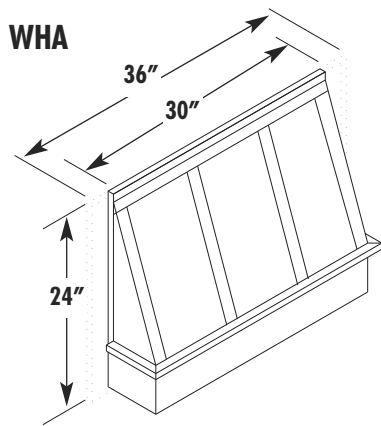

Liners are sold separately and are not included in the price. See page 49 for more liner specifications.

CUSTOM WOOD HOOD PRICING

UNFINISHED

Wood Hood Code	Red Oak	Knotty Pine	Maple	Hickory	Cherry
WHA30	X	X	X	X	X
WHA36	X	X	X	X	X
WHB30	X	X	X	X	X
WHB36	X	X	X	X	X
WHC30	X	X	X	X	X
WHC36	X	X	X	X	X
WHD30	X	X	X	X	X
WHD36	X	X	X	X	X
WHF30	X	X	X	X	X
WHF36	X	X	X	X	X

PREFINISHED GLAZED ADD \$95.00

Wood Hood Code	Red Oak	Knotty Pine	Maple	Hickory	Cherry
WHA30	X	X	X	X	X
WHA36	X	X	X	X	X
WHB30	X	X	X	X	X
WHB36	X	X	X	X	X
WHC30	X	X	X	X	X
WHC36	X	X	X	X	X
WHD30	X	X	X	X	X
WHD36	X	X	X	X	X
WHF30	X	X	X	X	X
WHF36	X	X	X	X	X

The layout of each of these hoods will be based on your specified ceiling height.

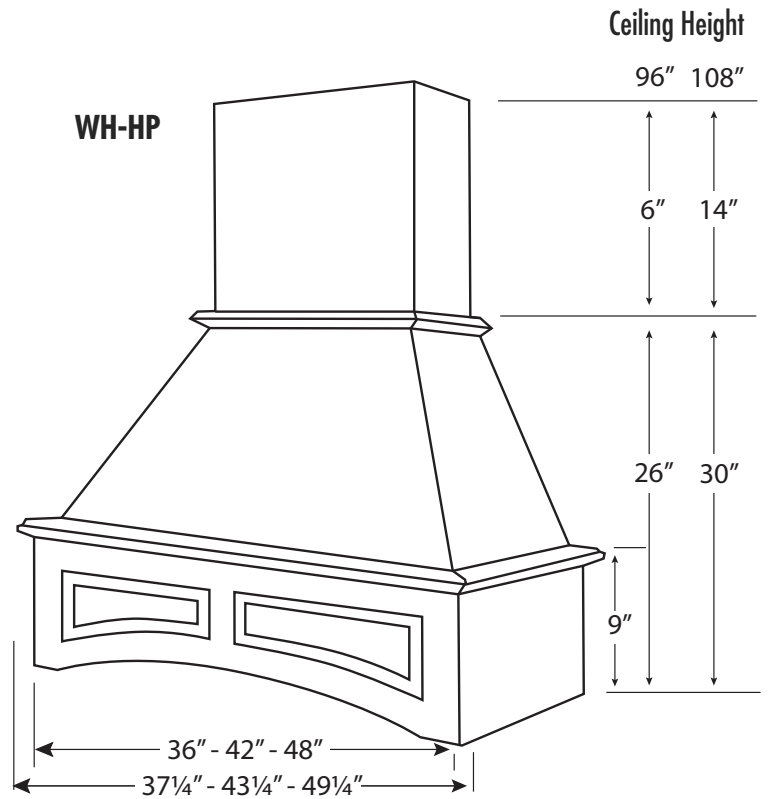
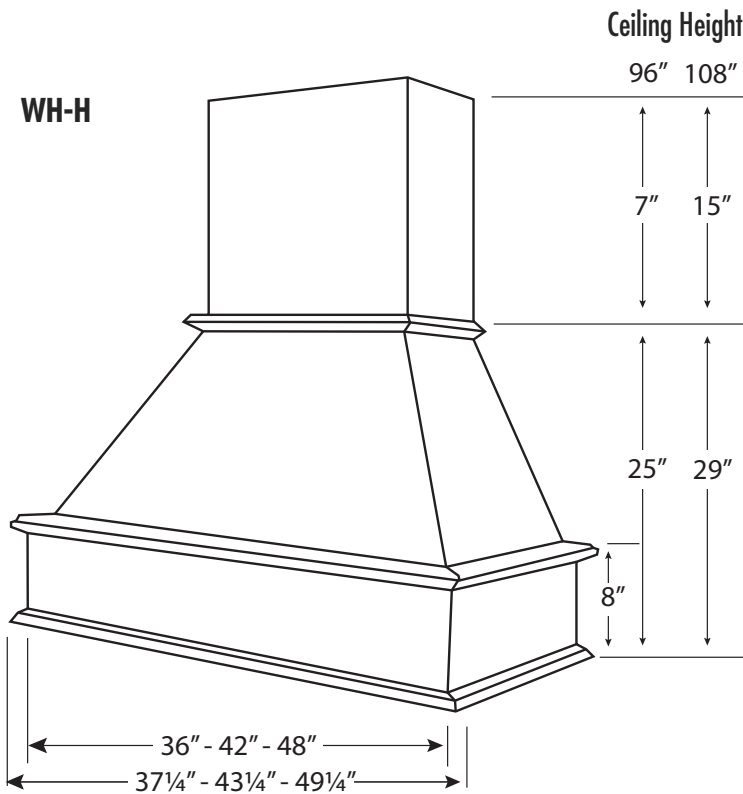

CUSTOM WOOD HOODS PRICING

UNFINISHED

Wood Hood Code	Red Oak	Alder	Maple	Hickory	Cherry
WH-H36	X	X	X	X	X
WH-H42	X	X	X	X	X
WH-H48	X	X	X	X	X
WH-HP36	X	X	X	X	X
WH-HP42	X	X	X	X	X
WH-HP48	X	X	X	X	X

PREFINISHED GLAZED ADD \$XX.XX

Wood Hood Code	Red Oak	Alder	Maple	Hickory	Cherry
WH-H36	X	X	X	X	X
WH-H42	X	X	X	X	X
WH-H48	X	X	X	X	X
WH-HP36	X	X	X	X	X
WH-HP42	X	X	X	X	X
WH-HP48	X	X	X	X	X

Liners are sold separately and are not included in the price. See page 49 for liner specifications.

49 WOOD HOOD LINER AND BLOWER UNITS

Liners are **NOT** included with the wood hoods and must be ordered separately.

For wood hood styles WHA, WHB, WHC, WHD and WHF order one of these liners:

- 90654SM2 – 30" Silver Liner: **COST \$XXX.XX**
- 90655SM2 – 36" Silver Liner: **COST \$XXX.XX**

For wood hood styles WH-H and WH-HP order one of these liners:

- 905B36SM1 – 36" Silver Liner: **COST \$XXX.XX**
- 905B42SM1 – 42" Silver Liner: **COST \$XXX.XX**
- 905B48SM1 – 48" Silver Liner: **COST \$XXX.XX**

Liner

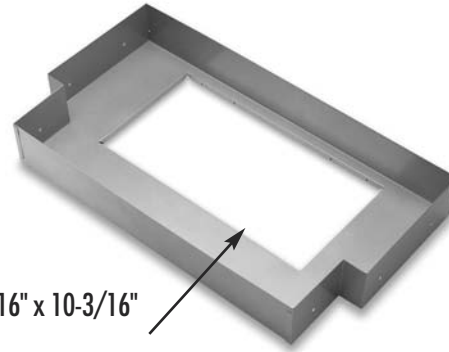

Opening is 19-7/16" x 10-3/16"

Blower Units are **NOT** included and must be ordered separately.

Choose from the following models from the **BROAN** select series.

BROAN Blower Units

Select Series Ventilation Power Module: RHVBB20SM

COST: \$XXX.XX Each

- 390 CFM / 6 sones
- Silver Metallic Finish
- Three-speed slide control
- Heat Sentry detects excessive heat and adjusts speed automatically
- Dual 40 watt lighting (not included)

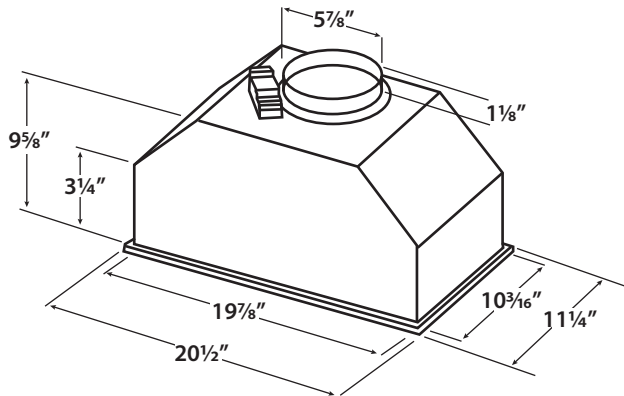

Select Series Ventilation Power Module: RHVBB10SM

COST: \$XXX.XX Each

- 250 CFM / 8 sones
- Silver Metallic Finish
- Two-speed motor, rocker control
- Dual 40 watt lighting (not included)

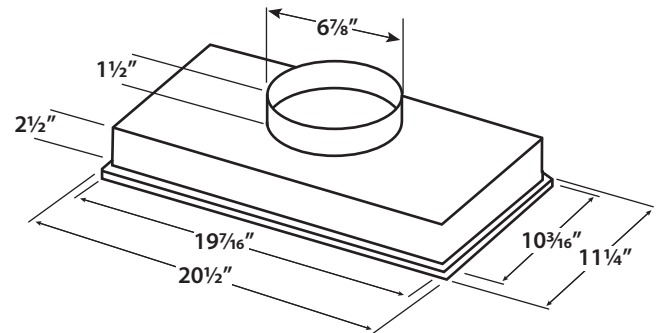

BROAN Blower Unit

Select Series RHVBB30SS - Internal Blower

COST: \$XXX.XX Each

- 500 CFM / 8.2 sones
- Stainless Steel Finish
- Push button controls
- Two 20 watt halogen lamps included
- Heat Sentry detects excessive heat and adjusts speed automatically
- Quiet centrifugal blower

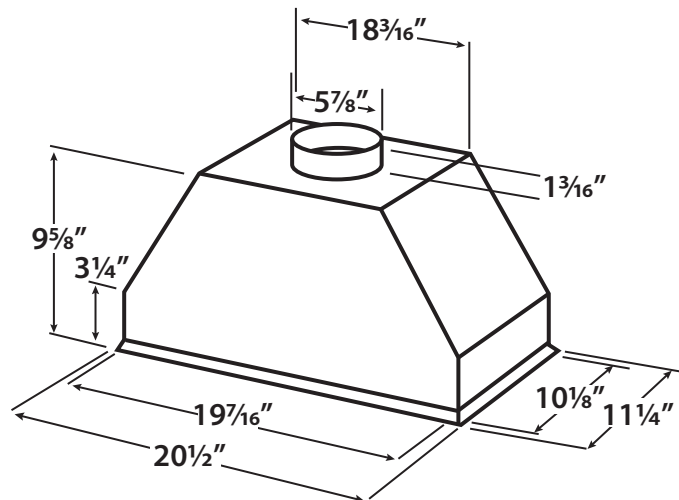

AG-ANGLED

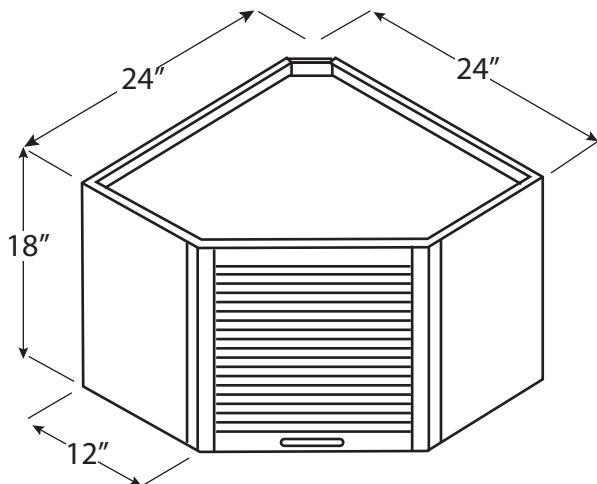

AG-STRAIGHT

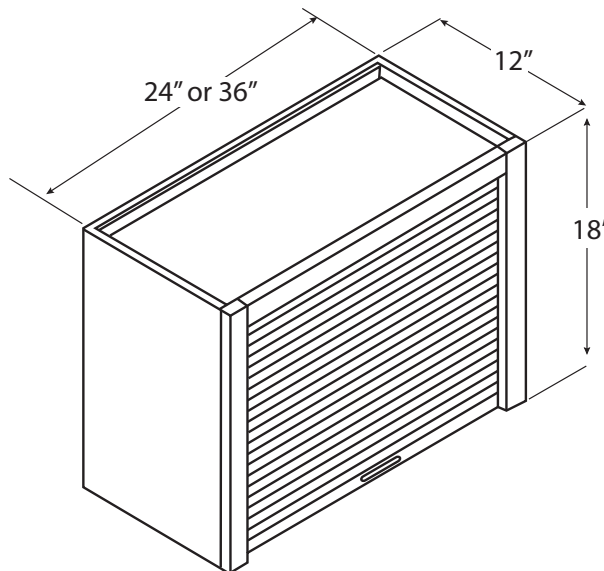

AG-STRAIGHT W/DOORS

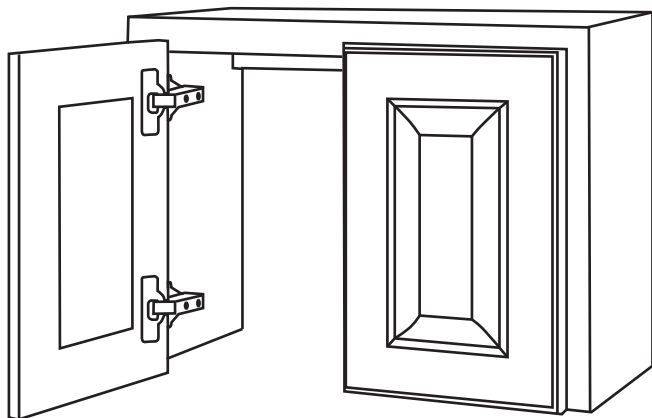

- Tambour door available in Alder, Maple, Oak and Cherry and sprayed to match.
- Price includes your choice of 5-Piece door or Tambour style door.
- Top rail is 3" high. Opening is 15" high.
- 36" is maximum width for proper operation of tambour door.

APPLIANCE GARAGE PRICING

UNFINISHED

Appliance Garage Code	Red Oak	Hard Maple	Cherry	Alder
AG 24" Straight	X	X	X	X
AG 36" Straight	X	X	X	X
AG 24" Angled	X	X	X	X

PREFINISHED GLAZED ADD \$XX.XX

Appliance Garage Code	Red Oak	Hard Maple	Cherry	Alder
AG 24" Straight	X	X	X	X
AG 36" Straight	X	X	X	X
AG 24" Angled	X	X	X	X

51 MANTEL SHELF

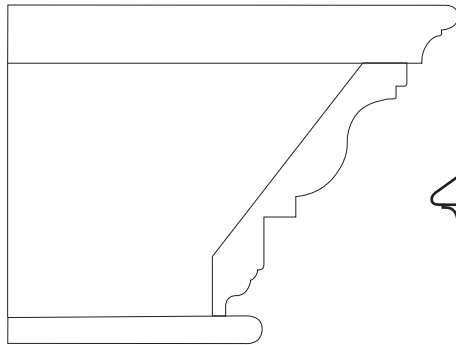

FPMS-1

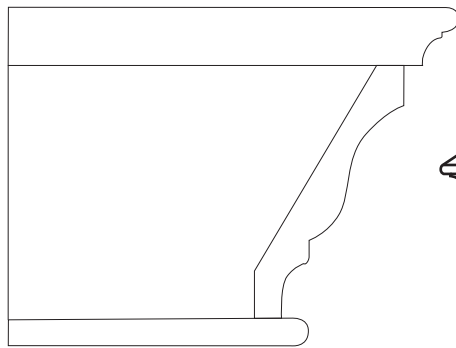
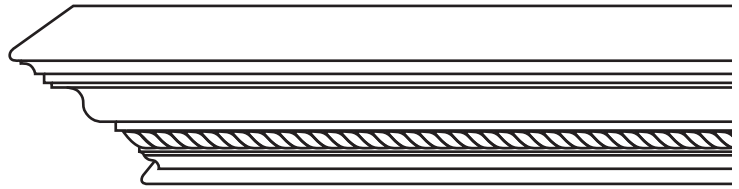

FPMS-2

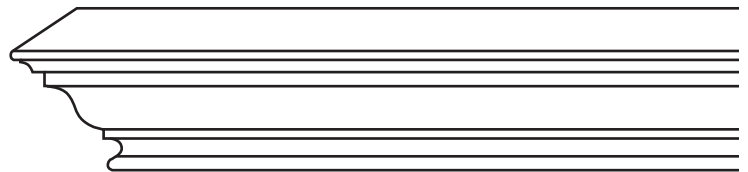

MANTEL SHELF PRICING

All mantel lengths will be rounded up to the next whole foot for pricing, but each mantel will be built to your specified size.

UNFINISHED

LENGTH	Red Oak	Hard Maple	Cherry
6'	X	X	X
7'	X	X	X
8'	X	X	X
9'	X	X	X
10'	X	X	X

PREFINISHED - (Stained Only)

LENGTH	Red Oak	Hard Maple	Cherry
6'	X	X	X
7'	X	X	X
8'	X	X	X
9'	X	X	X
10'	X	X	X

Style FPMS-1 Applied Moulding Cost per foot includes any stock wood species.

See page 57 for sketches of mouldings.

V-103 Rope	X per foot
V-104 Dentil	X per foot
V-110 Egg & Dart	X per foot

GLAZED - (Stained and Wiped Glaze)

LENGTH	Red Oak	Hard Maple	Cherry
6'	X	X	X
7'	X	X	X
8'	X	X	X
9'	X	X	X
10'	X	X	X

FLUTED RAILS: Standard rails are 3/4" thick, the flutes are 1/2" wide with 1/2" wide spacing between them.

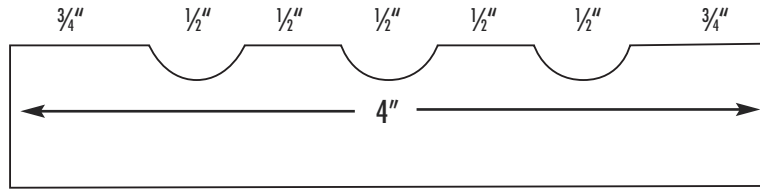

WHEN ORDERING FLUTED RAILS

1. Specify the number of flutes per piece.
2. Order the exact width and length of each piece. Pricing will be figured in increments of 1" widths but they will be cut to your specified size.
3. Specify the distance down from the top to start the flute and the distance up from the bottom to stop the flute.
4. Specify if there will be an integral rosette used.

FLUTED RAILS

WIDTH IN INCHES	UNFINISHED COST PER FOOT							PREFINISHED COST PER FOOT						
	2"	3"	4"	5"	6"	7"	8"	2"	3"	4"	5"	6"	7"	8"
Alder	X	X	X	X	X	X	X	X	X	X	X	X	X	X
Alder White	X	X	X	X	X	X	X	X	X	X	X	X	X	X
Beech European	X	X	X	X	X	X	X	X	X	X	X	X	X	X
Birch Red	X	X	X	X	X	X	X	X	X	X	X	X	X	X
Birch White	X	X	X	X	X	X	X	X	X	X	X	X	X	X
Butternut	X	X	X	X	X	X	X	X	X	X	X	X	X	X
Cedar Knotty	X	X	X	X	X	X	X	X	X	X	X	X	X	X
Cherry	X	X	X	X	X	X	X	X	X	X	X	X	X	X
Hickory	X	X	X	X	X	X	X	X	X	X	X	X	X	X
Lyptus	X	X	X	X	X	X	X	X	X	X	X	X	X	X
Mahogany African	X	X	X	X	X	X	X	X	X	X	X	X	X	X
Mahogany Genuine	X	X	X	X	X	X	X	X	X	X	X	X	X	X
Maple Hard White	X	X	X	X	X	X	X	X	X	X	X	X	X	X
Maple Hard White Birdseye	X	X	X	X	X	X	X	X	X	X	X	X	X	X
Maple Soft	X	X	X	X	X	X	X	X	X	X	X	X	X	X
Oak Red	X	X	X	X	X	X	X	X	X	X	X	X	X	X
Oak Red Quarter Sawn	X	X	X	X	X	X	X	X	X	X	X	X	X	X
Oak Red Rift	X	X	X	X	X	X	X	X	X	X	X	X	X	X
Oak White	X	X	X	X	X	X	X	X	X	X	X	X	X	X
Oak White Quarter Sawn	X	X	X	X	X	X	X	X	X	X	X	X	X	X
Oak White Rift	X	X	X	X	X	X	X	X	X	X	X	X	X	X
Paint Grade	X	X	X	X	X	X	X	X	X	X	X	X	X	X
Pine White Clear	X	X	X	X	X	X	X	X	X	X	X	X	X	X
Poplar	X	X	X	X	X	X	X	X	X	X	X	X	X	X
Walnut	X	X	X	X	X	X	X	X	X	X	X	X	X	X
	GLAZING Upcharge per Foot							X	X	X	X	X	X	X

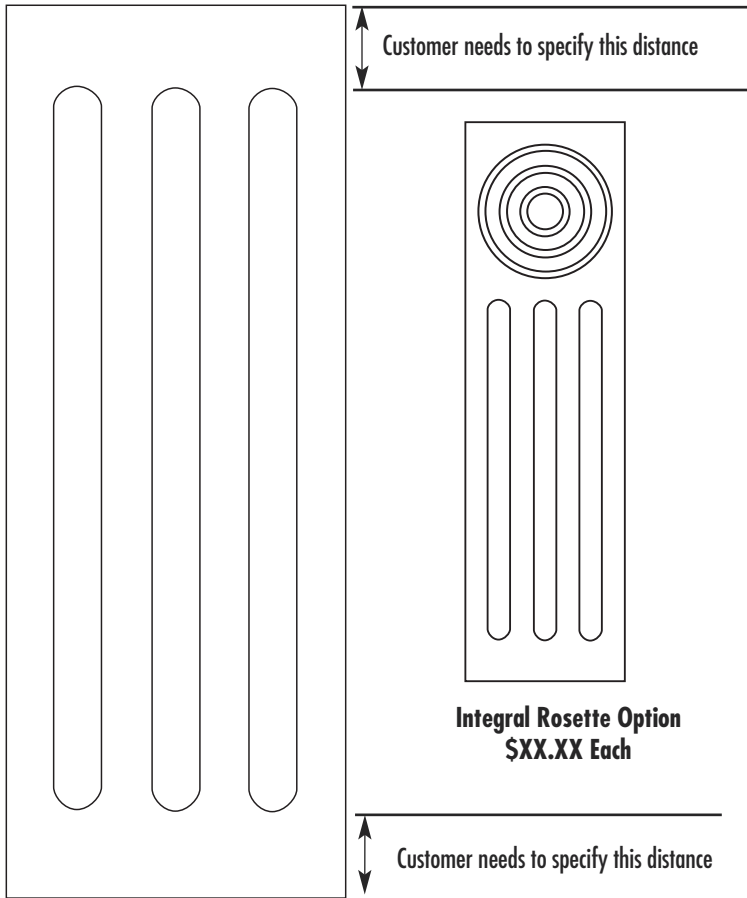

ROSETTES & PLINTHS
UNFINISHED PRICED PER SQUARE FOOT
½ SQ FT Minimum for pricing

WOOD SPECIES	¾"	1"
Alder	X	X
Ash White	X	NA
Beech European	X	NA
Birch Red	X	NA
Birch White	X	NA
Butternut	X	NA
Cedar Knotty	X	NAr
Cherry	X	X
Hickory	X	X
Lyptus	X	NA
Mahogany African	X	NA
Mahogany Genuine	X	NA
Maple Hard White	X	X
Maple Hard White Birdseye	X	NA
Maple Soft	X	X
Oak Red	X	X
Oak Red Quarter Sawn	X	NA
Oak Red Rift	X	NA
Oak White	X	NA
Oak White Quarter Sawn	X	NA
Oak White Rift	X	NA
Paint Grade	X	X
Pine White Clear	X	NA
Poplar	X	NA
Walnut	X	NA

ROSETTE

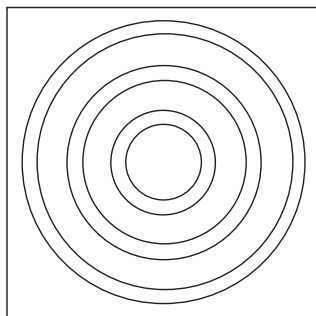

Must Specify Size
(Overall size will determine how many rings there will be.)

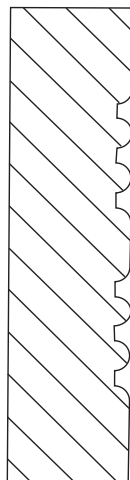

¾" or 1"

*Add Prefinished cost per sq ft as shown on page 36.

PLINTH BLOCK

Available in ¾" or 1" thickness.
Must Specify Size

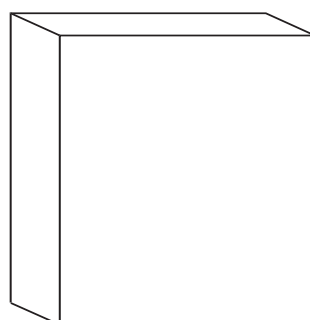

The following routed outside edges are available:

- E-101 E-114 E-121
- E-105 E-115 E-123
- E-106 E-116 E-124
- E-108 E-117 E-126
- E-110 E-118 E-127

MOULDINGS

* See pages 59 & 60 for pricing.

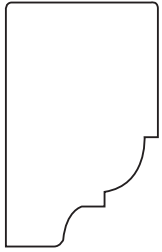

V-8
1 1/4" Cove

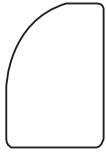

V-10
3/4" Shoe

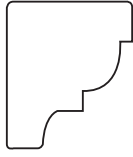

V-15
3/4" Moulding

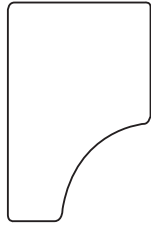

V-19
1 1/8" Cove

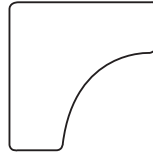

V-20
3/4" Moulding

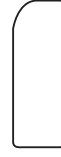

V-22
3/4" Scribe



V-23
3/4" Double Scribe

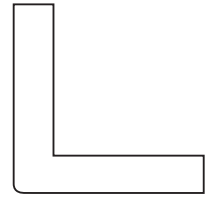

V-34
1" Outside Corner

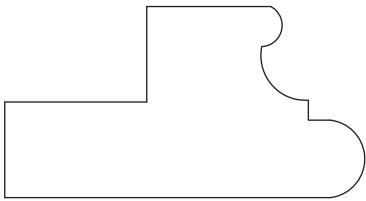

V-26
1 7/8" Wide x 1" Thick Under Cabinet Moulding

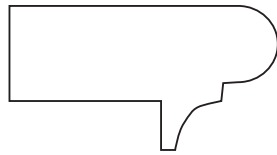

V-63
1 1/16" Wainscot Cap

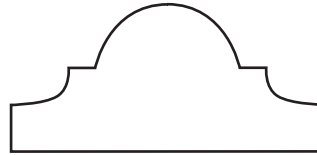

V-67
1 5/8" x 3/4" Moulding

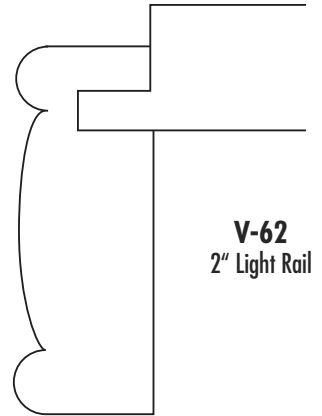

V-62
2" Light Rail

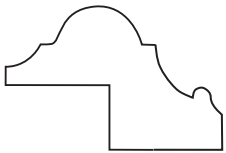

V-100
1 1/8" Door Moulding

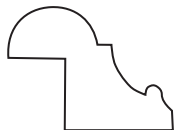

V-109
7/8" Door Moulding

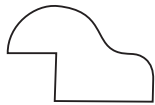

V-105
3/4" Door Moulding



V-102
5/8" Door Moulding



SR-107
3/4" Door Moulding



V-108
5/8" Wood Retainer Strip



V-106 3/8" Door Rope Moulding



V-112 3/8" Door Bead Moulding



V-41
2 1/4" Casing

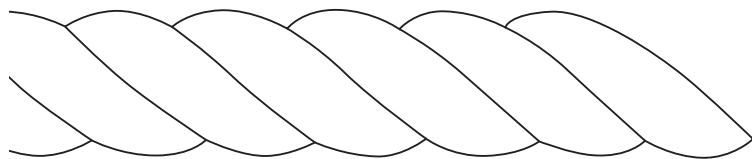

V-103 3/4" Rope Moulding



V-42
2 1/4" Casing

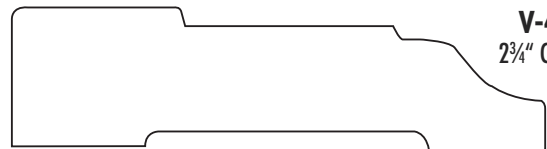

V-43
2 3/4" Casing

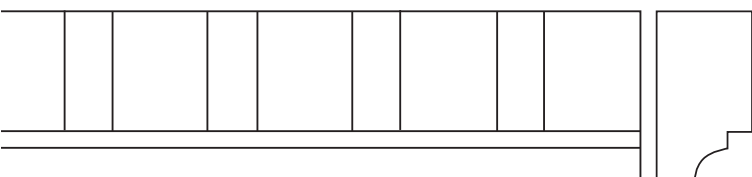

V-104 7/8" Dentil Moulding

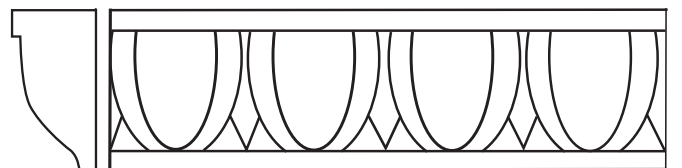

V-110 3/8" x 3/4" Egg & Dart

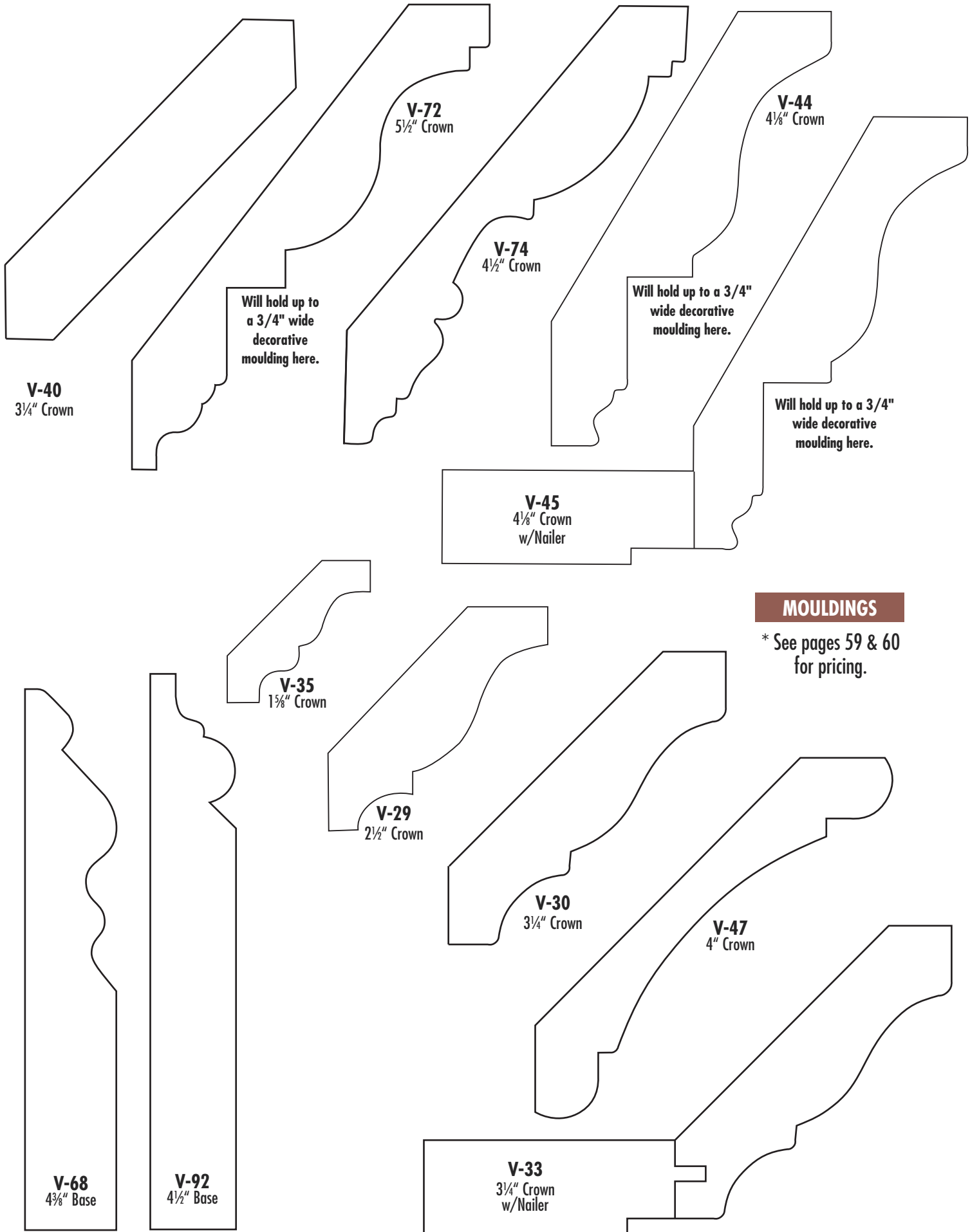

V-40
3 1/4" Crown

Will hold up to a 3/4" wide decorative moulding here.

V-72
5 1/2" Crown

V-74
4 1/2" Crown

Will hold up to a 3/4" wide decorative moulding here.

V-44
4 1/8" Crown

Will hold up to a 3/4" wide decorative moulding here.

V-45
4 1/8" Crown
w/Nailer

MOULDINGS

* See pages 59 & 60 for pricing.

V-35
1 5/8" Crown

V-29
2 1/2" Crown

V-30
3 1/4" Crown

V-47
4" Crown

V-68
4 3/8" Base

V-92
4 1/2" Base

V-33
3 1/4" Crown
w/Nailer

UNFINISHED MOULDINGS – PRICED PER 8’ LENGTH

WOOD SPECIES	V-8	V-10	V-12	V-15	V-19	V-20	V-22	V-23	V-26	V-29	V-30	V-33	V-34	V-35	V-40	V-41	V-42	V-43	V-44
Alder	X	X	X	X	X	X	X	X	X	X	X	X	X	X	X	X	X	X	X
Ash White	X	X	X	X	X	X	X	X	X	X	X	X	X	X	X	X	X	X	X
Beech European	X	X	X	X	X	X	X	X	X	X	X	X	X	X	X	X	X	X	X
Birch Red	X	X	X	X	X	X	X	X	X	X	X	X	X	X	X	X	X	X	X
Birch White	X	X	X	X	X	X	X	X	X	X	X	X	X	X	X	X	X	X	X
Butternut	X	X	X	X	X	X	X	X	X	X	X	X	X	X	X	X	X	X	X
Cedar Knotty	X	X	X	X	X	X	X	X	X	X	X	X	X	X	X	X	X	X	X
Cherry	X	X	X	X	X	X	X	X	X	X	X	X	X	X	X	X	X	X	X
Hickory	X	X	X	X	X	X	X	X	X	X	X	X	X	X	X	X	X	X	X
Lyptus	X	X	X	X	X	X	X	X	X	X	X	X	X	X	X	X	X	X	X
Mahogany African	X	X	X	X	X	X	X	X	X	X	X	X	X	X	X	X	X	X	X
Mahogany Genuine	X	X	X	X	X	X	X	X	X	X	X	X	X	X	X	X	X	X	X
Maple Hard White	X	X	X	X	X	X	X	X	X	X	X	X	X	X	X	X	X	X	X
Maple Hard White Birdseye	X	X	X	X	X	X	X	X	X	X	X	X	X	X	X	X	X	X	X
Maple Soft	X	X	X	X	X	X	X	X	X	X	X	X	X	X	X	X	X	X	X
Oak Red	X	X	X	X	X	X	X	X	X	X	X	X	X	X	X	X	X	X	X
Oak Red Quarter Sawn	X	X	X	X	X	X	X	X	X	X	X	X	X	X	X	X	X	X	X
Oak Red Rift	X	X	X	X	X	X	X	X	X	X	X	X	X	X	X	X	X	X	X
Oak White	X	X	X	X	X	X	X	X	X	X	X	X	X	X	X	X	X	X	X
Oak White Quarter Sawn	X	X	X	X	X	X	X	X	X	X	X	X	X	X	X	X	X	X	X
Oak White Rift	X	X	X	X	X	X	X	X	X	X	X	X	X	X	X	X	X	X	X
Paint Grade	X	X	X	X	X	X	X	X	X	X	X	X	X	X	X	X	X	X	X
Pine White Clear	X	X	X	X	X	X	X	X	X	X	X	X	X	X	X	X	X	X	X
Poplar	X	X	X	X	X	X	X	X	X	X	X	X	X	X	X	X	X	X	X
Walnut	X	X	X	X	X	X	X	X	X	X	X	X	X	X	X	X	X	X	X

PREFINISHED MOULDINGS – PRICED PER 8’ LENGTH

WOOD SPECIES	V-8	V-10	V-12	V-15	V-19	V-20	V-22	V-23	V-26	V-29	V-30	V-33	V-34	V-35	V-40	V-41	V-42	V-43	V-44
Alder	X	X	X	X	X	X	X	X	X	X	X	X	X	X	X	X	X	X	X
White	X	X	X	X	X	X	X	X	X	X	X	X	X	X	X	X	X	X	X
Beech European	X	X	X	X	X	X	X	X	X	X	X	X	X	X	X	X	X	X	X
Birch Red	X	X	X	X	X	X	X	X	X	X	X	X	X	X	X	X	X	X	X
Birch White	X	X	X	X	X	X	X	X	X	X	X	X	X	X	X	X	X	X	X
Butternut	X	X	X	X	X	X	X	X	X	X	X	X	X	X	X	X	X	X	X
Cedar Knotty	X	X	X	X	X	X	X	X	X	X	X	X	X	X	X	X	X	X	X
Cherry	X	X	X	X	X	X	X	X	X	X	X	X	X	X	X	X	X	X	X
Hickory	X	X	X	X	X	X	X	X	X	X	X	X	X	X	X	X	X	X	X
Lyptus	X	X	X	X	X	X	X	X	X	X	X	X	X	X	X	X	X	X	X
Mahogany African	X	X	X	X	X	X	X	X	X	X	X	X	X	X	X	X	X	X	X
Mahogany Genuine	X	X	X	X	X	X	X	X	X	X	X	X	X	X	X	X	X	X	X
Maple Hard White	X	X	X	X	X	X	X	X	X	X	X	X	X	X	X	X	X	X	X
Maple Hard White Birdseye	X	X	X	X	X	X	X	X	X	X	X	X	X	X	X	X	X	X	X
Maple Soft	X	X	X	X	X	X	X	X	X	X	X	X	X	X	X	X	X	X	X
Oak Red	X	X	X	X	X	X	X	X	X	X	X	X	X	X	X	X	X	X	X
Oak Red Quarter Sawn	X	X	X	X	X	X	X	X	X	X	X	X	X	X	X	X	X	X	X
Oak Red Rift	X	X	X	X	X	X	X	X	X	X	X	X	X	X	X	X	X	X	X
Oak White	X	X	X	X	X	X	X	X	X	X	X	X	X	X	X	X	X	X	X
Oak White Quarter Sawn	X	X	X	X	X	X	X	X	X	X	X	X	X	X	X	X	X	X	X
Oak White Rift	X	X	X	X	X	X	X	X	X	X	X	X	X	X	X	X	X	X	X
Paint Grade	X	X	X	X	X	X	X	X	X	X	X	X	X	X	X	X	X	X	X
Pine White Clear	X	X	X	X	X	X	X	X	X	X	X	X	X	X	X	X	X	X	X
Poplar	X	X	X	X	X	X	X	X	X	X	X	X	X	X	X	X	X	X	X
Walnut	X	X	X	X	X	X	X	X	X	X	X	X	X	X	X	X	X	X	X
GLAZING Upcharge Per 8'	X	X	X	X	X	X	X	X	X	X	X	X	X	X	X	X	X	X	X

All shaded items are stock. All nonstock items may be subject to SXXX.XX set-up charge.

UNFINISHED MOULDINGS – PRICED PER 8’ LENGTH																			CONTINUED	
WOOD SPECIES	V-45	V-47	V-62	V-63	V-67	V-68	V-72	V-74	V-92	V-100	V-102	V-103	V-104	V-105	V-106	SR-107	V-108	V-109	V-110	V-112
Alder	X	X	X	X	X	X	X	X	X	X	X	NA	NA	X	NA	X	X	X	X	X
Ash White	X	X	X	X	X	X	X	X	X	X	X	NA	NA	X	NA	X	X	X	NA	NA
Beech European	X	X	X	X	X	X	X	X	X	X	X	NA	NA	X	NA	X	X	X	NA	NA
Birch Red	X	X	X	X	X	X	X	X	X	X	X	NA	NA	X	NA	X	X	X	NA	NA
Birch White	X	X	X	X	X	X	X	X	X	X	X	NA	NA	X	NA	X	X	X	NA	NA
Butternut	X	X	X	X	X	X	X	X	X	X	X	NA	NA	X	NA	X	X	X	NA	NA
Cedar Knotty	X	X	X	X	X	X	X	X	X	X	X	NA	NA	X	NA	X	X	X	NA	NA
Cherry	X	X	X	X	X	X	X	X	X	X	X	X	X	X	X	X	X	X	X	X
Hickory	X	X	X	X	X	X	X	X	X	X	X	NA	NA	X	NA	X	X	X	NA	NA
Lyptus	X	X	X	X	X	X	X	X	X	X	X	NA	NA	X	NA	X	X	X	NA	NA
Mahogany African	X	X	X	X	X	X	X	X	X	X	X	NA	NA	X	NA	X	X	X	NA	NA
Mahogany Genuine	X	X	X	X	X	X	X	X	X	X	X	NA	NA	X	NA	X	X	X	NA	NA
Maple Hard White	X	X	X	X	X	X	X	X	X	X	X	X	X	X	X	X	X	X	X	X
Maple Hard White Birdseye	X	X	X	X	X	X	X	X	X	X	X	NA	NA	X	NA	X	X	X	NA	NA
Maple Soft	X	X	X	X	X	X	X	X	X	X	X	NA	NA	X	NA	X	X	X	NA	NA
Oak Red	X	X	X	X	X	X	X	X	X	X	X	X	X	X	X	X	X	X	X	X
Oak Red Quarter Sawn	X	X	X	X	X	X	X	X	X	X	X	NA	NA	X	NA	X	X	X	NA	NA
Oak Red Rift	X	X	X	X	X	X	X	X	X	X	X	NA	NA	X	NA	X	X	X	NA	NA
Oak White	X	X	X	X	X	X	X	X	X	X	X	NA	NA	X	NA	X	X	X	NA	NA
Oak White Quarter Sawn	X	X	X	X	X	X	X	X	X	X	X	NA	NA	X	NA	X	X	X	NA	NA
Oak White Rift	X	X	X	X	X	X	X	X	X	X	X	NA	NA	X	NA	X	X	X	NA	NA
Paint Grade	X	X	X	X	X	X	X	X	X	X	X	NA	NA	X	NA	X	X	X	NA	NA
Pine White Clear	X	X	X	X	X	X	X	X	X	X	X	NA	NA	X	NA	X	X	X	NA	NA
Poplar	X	X	X	X	X	X	X	X	X	X	X	NA	NA	X	NA	X	X	X	NA	NA
Walnut	X	X	X	X	X	X	X	X	X	X	X	NA	NA	X	NA	X	X	X	NA	NA

PREFINISHED MOULDINGS – PRICED PER 8’ LENGTH																			CONTINUED	
WOOD SPECIES	V-45	V-47	V-62	V-63	V-67	V-68	V-72	V-74	V-92	V-100	V-102	V-103	V-104	V-105	V-106	SR-107	V-108	V-109	V-110	V-112
Alder	X	X	X	X	X	X	X	X	X	X	X	NA	NA	X	NA	X	X	X	X	X
Ash White	X	X	X	X	X	X	X	X	X	X	X	NA	NA	X	NA	X	X	X	NA	NA
Beech European	X	X	X	X	X	X	X	X	X	X	X	NA	NA	X	NA	X	X	X	NA	NA
Birch Red	X	X	X	X	X	X	X	X	X	X	X	NA	NA	X	NA	X	X	X	NA	NA
Birch White	X	X	X	X	X	X	X	X	X	X	X	NA	NA	X	NA	X	X	X	NA	NA
Butternut	X	X	X	X	X	X	X	X	X	X	X	NA	NA	X	NA	X	X	X	NA	NA
Cedar Knotty	SX	X	X	X	X	X	X	X	X	X	X	NA	NA	X	NA	X	X	X	NA	NA
Cherry	X	X	X	X	X	X	X	X	X	X	X	X	X	X	X	X	X	X	X	X
Hickory	SX	X	X	X	X	X	X	X	X	X	X	NA	NA	X	NA	X	X	X	NA	NA
Lyptus	X	X	X	X	X	X	X	X	X	X	X	NA	NA	X	NA	X	X	X	NA	NA
Mahogany African	X	X	X	X	X	X	X	X	X	X	X	NA	NA	X	NA	X	X	X	NA	NA
Mahogany Genuine	X	X	X	X	X	X	X	X	X	X	X	NA	NA	X	NA	X	X	X	NA	NA
Maple Hard White	X	X	X	X	X	X	X	X	X	X	X	X	X	X	X	X	X	X	X	X
Maple Hard White Birdseye	X	X	X	X	X	X	X	X	X	X	X	NA	NA	X	NA	X	X	X	NA	NA
Maple Soft	X	X	X	X	X	X	X	X	X	X	X	NA	NA	X	NA	X	X	X	NA	NA
Oak Red	X	X	X	X	X	X	X	X	X	X	X	X	X	X	X	X	X	X	X	X
Oak Red Quarter Sawn	X	X	X	X	X	X	X	X	X	X	X	NA	NA	X	NA	X	X	X	NA	NA
Oak Red Rift	X	X	X	X	X	X	X	X	X	X	X	NA	NA	X	NA	X	X	X	NA	NA
Oak White	X	X	X	X	X	X	X	X	X	X	X	NA	NA	X	NA	X	X	X	NA	NA
Oak White Quarter Sawn	X	X	X	X	X	X	X	X	X	X	X	NA	NA	X	NA	X	X	X	NA	NA
Oak White Rift	X	X	X	X	X	X	X	X	X	X	X	NA	NA	X	NA	X	X	X	NA	NA
Paint Grade	X	X	X	X	X	X	X	X	X	X	X	NA	NA	X	NA	X	X	X	NA	NA
Pine White Clear	X	X	X	X	X	X	X	X	X	X	X	NA	NA	X	NA	X	X	X	NA	NA
Poplar	X	X	X	X	X	X	X	X	X	X	X	NA	NA	X	NA	X	X	X	NA	NA
Walnut	X	X	X	X	X	X	X	X	X	X	X	NA	NA	X	NA	X	X	X	NA	NA
GLAZING Upcharge Per 8'	X	X	X	X	X	X	X	X	X	X	X	X	X	X	X	X	X	X	X	X

All shaded items are stock. All nonstock items may be subject to SXXX.XX set-up charge.

61 3/4 S4S FACE FRAME STOCK

3/4 SOLID FACE FRAME STOCK - PRICING PER 8' LENGTH UNFINISHED

WOOD SPECIES	1/2"	1"	1-1/2"	2"	2-1/2"	3"	3-1/2"	4"	4-1/2"	5"	5-1/2"	6"	7"	8"
Alder	X	X	X	X	X	X	X	X	X	X	X	X	X	X
Ash White	X	X	X	X	X	X	X	X	X	X	X	X	X	X
Beech European	X	X	X	X	X	X	X	X	X	X	X	X	X	X
Birch Red	X	X	X	X	X	X	X	X	X	X	X	X	X	X
Birch White	X	X	X	X	X	X	X	X	X	X	X	X	X	X
Butternut	X	X	X	X	X	X	X	X	X	X	X	X	X	X
Cedar Knotty	X	X	X	X	X	X	X	X	X	X	X	X	X	X
Cherry	X	X	X	X	X	X	X	X	X	X	X	X	X	X
Hickory	X	X	X	X	X	X	X	X	X	X	X	X	X	X
Lyptus	X	X	X	X	X	X	X	X	X	X	X	X	X	X
Mahogany African	X	X	X	X	X	X	X	X	X	X	X	X	X	X
Mahogany Genuine	X	X	X	X	X	X	X	X	X	X	X	X	X	X
Maple Hard White	X	X	X	X	X	X	X	X	X	X	X	X	X	X
Maple Hard White Birdseye	X	X	X	X	X	X	X	X	X	X	X	X	X	X
Maple Soft	X	X	X	X	X	X	X	X	X	X	X	X	X	X
Oak Red	X	X	X	X	X	X	X	X	X	X	X	X	X	X
Oak Red Quarter Sawn	X	X	X	X	X	X	X	X	X	X	X	X	X	X
Oak Red Rift	X	X	X	X	X	X	X	X	X	X	X	X	X	X
Oak White	X	X	X	X	X	X	X	X	X	X	X	X	X	X
Oak White Quarter Sawn	X	X	X	X	X	X	X	X	X	X	X	X	X	X
Oak White Rift	X	X	X	X	X	X	X	X	X	X	X	X	X	X
Paint Grade	X	X	X	X	X	X	X	X	X	X	X	X	X	X
Pine White Clear	X	X	X	X	X	X	X	X	X	X	X	X	X	X
Poplar	X	X	X	X	X	X	X	X	X	X	X	X	X	X
Walnut	X	X	X	X	X	X	X	X	X	X	X	X	X	X

3/4 SOLID FACE FRAME STOCK - PRICING PER 8' LENGTH PREFINISHED (Prefinished pricing includes stain and varnish)

WOOD SPECIES	1/2"	1"	1-1/2"	2"	2-1/2"	3"	3-1/2"	4"	4-1/2"	5"	5-1/2"	6"	7"	8"
Alder	X	X	X	X	X	X	X	X	X	X	X	X	X	X
Ash White	X	X	X	X	X	X	X	X	X	X	X	X	X	X
Beech European	X	X	X	X	X	X	X	X	X	X	X	X	X	X
Birch Red	X	X	X	X	X	X	X	X	X	X	X	X	X	X
Birch White	X	X	X	X	X	X	X	X	X	X	X	X	X	X
Butternut	X	X	X	X	X	X	X	X	X	X	X	X	X	X
Cedar Knotty	X	X	X	X	X	X	X	X	X	X	X	X	X	X
Cherry	X	X	X	X	X	X	X	X	X	X	X	X	X	X
Hickory	X	X	X	X	X	X	X	X	X	X	X	X	X	X
Lyptus	X	X	X	X	X	X	X	X	X	X	X	X	X	X
Mahogany African	X	X	X	X	X	X	X	X	X	X	X	X	X	X
Mahogany Genuine	X	X	X	X	X	X	X	X	X	X	X	X	X	X
Maple Hard White	X	X	X	X	X	X	X	X	X	X	X	X	X	X
Maple Hard White Birdseye	X	X	X	X	X	X	X	X	X	X	X	X	X	X
Maple Soft	X	X	X	X	X	X	X	X	X	X	X	X	X	X
Oak Red	X	X	X	X	X	X	X	X	X	X	X	X	X	X
Oak Red Quarter Sawn	X	X	X	X	X	X	X	X	X	X	X	X	X	X
Oak Red Rift	X	X	X	X	X	X	X	X	X	X	X	X	X	X
Oak White	X	X	X	X	X	X	X	X	X	X	X	X	X	X
Oak White Quarter Sawn	X	X	X	X	X	X	X	X	X	X	X	X	X	X
Oak White Rift	X	X	X	X	X	X	X	X	X	X	X	X	X	X
Paint Grade	X	X	X	X	X	X	X	X	X	X	X	X	X	X
Pine White Clear	X	X	X	X	X	X	X	X	X	X	X	X	X	X
Poplar	X	X	X	X	X	X	X	X	X	X	X	X	X	X
Walnut	X	X	X	X	X	X	X	X	X	X	X	X	X	X
GLAZING Upcharge Per 8'	X	X	X	X	X	X	X	X	X	X	X	X	X	X

* Pricing based on 1/2" width increments, but material will be cut to your specifications.

1/4 SOLID FACE FRAME STOCK - PRICING PER 8' LENGTH UNFINISHED												
WOOD SPECIES	1/2"	1"	1-1/2"	2"	2-1/2"	3"	3-1/2"	4"	4-1/2"	5"	5-1/2"	6"
Alder	X	X	X	X	X	X	X	X	X	X	X	X
Ash White	X	X	X	X	X	X	X	X	X	X	X	X
Beech European	X	X	X	X	X	X	X	X	X	X	X	X
Birch Red	X	X	X	X	X	X	X	X	X	X	X	X
Birch White	X	X	X	X	X	X	X	X	X	X	X	X
Butternut	X	X	X	X	X	X	X	X	X	X	X	X
Cedar Knotty	X	X	X	X	X	X	X	X	X	X	X	X
Cherry	X	X	X	X	X	X	X	X	X	X	X	X
Hickory	X	X	X	X	X	X	X	X	X	X	X	X
Lyptus	X	X	X	X	X	X	X	X	X	X	X	X
Mahogany African	X	X	X	X	X	X	X	X	X	X	X	X
Mahogany Genuine	X	X	X	X	X	X	X	X	X	X	X	X
Maple Hard White	X	X	X	X	X	X	X	X	X	X	X	X
Maple Hard White Birdseye	X	X	X	X	X	X	X	X	X	X	X	X
Maple Soft	X	X	X	X	X	X	X	X	X	X	X	X
Oak Red	X	X	X	X	X	X	X	X	X	X	X	X
Oak Red Quarter Sawn	X	X	X	X	X	X	X	X	X	X	X	X
Oak Red Rift	X	X	X	X	X	X	X	X	X	X	X	X
Oak White	X	X	X	X	X	X	X	X	X	X	X	X
Oak White Quarter Sawn	X	X	X	X	X	X	X	X	X	X	X	X
Oak White Rift	X	X	X	X	X	X	X	X	X	X	X	X
Paint Grade	X	X	X	X	X	X	X	X	X	X	X	X
Pine White Clear	X	X	X	X	X	X	X	X	X	X	X	X
Poplar	X	X	X	X	X	X	X	X	X	X	X	X
Walnut	X	X	X	X	X	X	X	X	X	X	X	X

1/4 SOLID FACE FRAME STOCK - PRICING PER 8' LENGTH PREFINISHED (Prefinished pricing includes stain and varnish)												
WOOD SPECIES	1/2"	1"	1-1/2"	2"	2-1/2"	3"	3-1/2"	4"	4-1/2"	5"	5-1/2"	6"
Alder	X	X	X	X	X	X	X	X	X	X	X	X
Ash White	X	X	X	X	X	X	X	X	X	X	X	X
Beech European	X	X	X	X	X	X	X	X	X	X	X	X
Birch Red	X	X	X	X	X	X	X	X	X	X	X	X
Birch White	X	X	X	X	X	X	X	X	X	X	X	X
Butternut	X	X	X	X	X	X	X	X	X	X	X	X
Cedar Knotty	X	X	X	X	X	X	X	X	X	X	X	X
Cherry	X	X	X	X	X	X	X	X	X	X	X	X
Hickory	X	X	X	X	X	X	X	X	X	X	X	X
Lyptus	X	X	X	X	X	X	X	X	X	X	X	X
Mahogany African	X	X	X	X	X	X	X	X	X	X	X	X
Mahogany Genuine	X	X	X	X	X	X	X	X	X	X	X	X
Maple Hard White	X	X	X	X	X	X	X	X	X	X	X	X
Maple Hard White Birdseye	X	X	X	X	X	X	X	X	X	X	X	X
Maple Soft	X	X	X	X	X	X	X	X	X	X	X	X
Oak Red	X	X	X	X	X	X	X	X	X	X	X	X
Oak Red Quarter Sawn	X	X	X	X	X	X	X	X	X	X	X	X
Oak Red Rift	X	X	X	X	X	X	X	X	X	X	X	X
Oak White	X	X	X	X	X	X	X	X	X	X	X	X
Oak White Quarter Sawn	X	X	X	X	X	X	X	X	X	X	X	X
Oak White Rift	X	X	X	X	X	X	X	X	X	X	X	X
Paint Grade	X	X	X	X	X	X	X	X	X	X	X	X
Pine White Clear	X	X	X	X	X	X	X	X	X	X	X	X
Poplar	X	X	X	X	X	X	X	X	X	X	X	X
Walnut	X	X	X	X	X	X	X	X	X	X	X	X
GLAZING Upcharge Per 8'	X	X	X	X	X	X	X	X	X	X	X	X

* Pricing based on 1/2" width increments, but material will be cut to your specifications. *Materials over 6" wide are not available.

63 VENEERS AND PLYWOOD PANELS

PS = PLAIN SLICED • R = ROTARY
SHADED AREAS INDICATE ALL STOCK ITEMS.

* All plywoods can be cut to your specified size.
 * Full sheets of plywood must ship via Common Carrier.

UNFINISHED							96" x 48" CROSS GRAIN 1/4" PLYWOOD SHEETS ARE AVAILABLE IN RED OAK, HARD MAPLE & CHERRY. CALL FOR PRICING			
	VENEER						Full Sheets 48" x 96"	Pre-Cut to your specified sizes	Full Sheets 48" x 96"	Pre-Cut to your specified sizes
	Wood on Wood		Duraback		Pressure Sensitive Wood on Wood					
	24" x 96"	48" x 96"	24" x 96"	48" x 96"	24" x 96"	48" x 96"				
PS Red Oak	X	X	X	X	X	X	X	X	X	X
PS Maple	X	X	X	X	X	X	X	X	X	X
PS Cherry	X	X	X	X	X	X	X	X	X	X
PS Alder	X	X	X	X	X	X	X	X	NA	NA
PS Hickory	X	X	X	X	X	X	X	X	NA	NA
PS White Oak	X	X	X	X	X	X	X	X	NA	NA
PS Clear Pine	X	X	X	X	X	X	X	X	NA	NA
PS Knotty Pine	X	X	X	X	X	X	X	X	NA	NA
PS Walnut	X	X	X	X	X	X	X	X	NA	NA
PS White Ash	X	X	X	X	X	X	X	X	NA	NA
R U/W Birch	X	X	X	X	X	X	X	X	NA	NA

GLAZING UPCHARGE: 24" x 96" sheets add \$XX.XX per sheet Cut to size: add \$X.XX per sq. ft.
 48" x 96" sheets add \$XX.XX per sheet

Priced Per Sq Ft	Priced Per Sq Ft
------------------	------------------

96" x 48" CROSS GRAIN 1/4" PLYWOOD SHEETS ARE AVAILABLE IN RED OAK, HARD MAPLE & CHERRY. CALL FOR PRICING.

PREFINISHED (Prefinished price includes stain and varnish)										
	VENEER						Full Sheets 48" x 96"	Pre-Cut to your specified sizes	Full Sheets 48" x 96"	Pre-Cut to your specified sizes
	Wood on Wood		Duraback		Pressure Sensitive Wood on Wood					
	24" x 96"	48" x 96"	24" x 96"	48" x 96"	24" x 96"	48" x 96"				
PS Red Oak	X	X	X	X	X	X	X	X	X	X
PS Maple	X	X	X	X	X	X	X	X	X	X
PS Cherry	X	X	X	X	X	X	X	X	X	X
PS Alder	X	X	X	X	X	X	X	X	NA	NA
PS Hickory	X	X	X	X	X	X	X	X	NA	NA
PS White Oak	X	X	X	X	X	X	X	X	NA	NA
PS Clear Pine	X	X	X	X	X	X	X	X	NA	NA
PS Knotty Pine	X	X	X	X	X	X	X	X	NA	NA
PS Walnut	X	X	X	X	X	X	X	X	NA	NA
PS White Ash	X	X	X	X	X	X	X	X	NA	NA
R U/W Birch	X	X	X	X	X	X	X	X	NA	NA

Priced Per Sq Ft	Priced Per Sq Ft
------------------	------------------

PRODUCT INFORMATION NOTE: Duraback veneer is the ONLY veneer we will paint. It is shipped flat to prevent cracking.

Veneers: Wood on Wood: This is a 2-ply veneer sheet consisting of an A-Grade wood face laminated to a sturdy veneer backer of the same or similar wood species.

DuraBack: A-Grade Wood Veneer with a backing material similar to plastic laminate.

Pressure Sensitive Wood on Wood Veneer: 2-ply veneer A-Grade Wood face with 3M™ "Peel and Stick" adhesive back.

1/4" Thick Plywood: A-Grade Face Wood Veneer. • **1/8" Thick Plywood:** A-Grade Face Wood Veneer.

See **APPLICATION INSTRUCTIONS** on our website: www.valleycustomdoor.com. Click on **Millwork/Refacing**.

Mantel & Surrounds Pricing Guide



Valley Custom Door

65 MANTELS AND SURROUNDS

Pricing: All published prices are LIST PRICES. Custom mantels and surrounds not seen in this book will require special pricing and may not be eligible for discounts. See page 60 for pricing.

Ordering Mantels and Surrounds:

1. All items must be ordered on our Valley Custom Door order forms. Each different style of Mantel/Surround and Upper Panel has its own order form. Please make photocopies of the order forms provided for you in this book.
2. All orders must be received by fax or mailed to us — NO PHONE ORDERS WILL BE ACCEPTED.

Mail to: Valley Custom Door, Attention: Mantel Order Dept., 845 Prosper Road, De Pere, WI 54115

Fax: 1-920-336-5956

Valley Custom Door will guarantee the order will be shipped as it was ordered. Orders will be acknowledged for the purpose of knowing they were received, not for making changes.

3. Mandatory size dimensions that must be filled in are:

A. Fireplace opening size including surrounding face material. We recommend that you measure the height of the fireplace face material and subtract $\frac{1}{2}$ ". We recommend that you measure the width of the fireplace face material and subtract 1". This will allow the mantel surround to overlay the face material by $\frac{1}{2}$ " on each of the three (3) sides.

B. Depth of tile or brick on back wall. We recommend that you take the actual depth of the face material and add $\frac{1}{4}$ " to allow for custom fitting if necessary. Moulding will be provided to cover any unevenness of the face material. *Note: It will be assumed that if a size dimension is missing on your order form, we are to use the standard size listed.*

4. Crown Moulding on the Upper Panels will be our standard V-30 ($3\frac{1}{4}$ " wide). The moulding will be shipped loose and must be applied to the Upper Panel at the job site.
5. Please note the minimum sizes printed on the order forms for some of the mantel components. Be certain you have allowed for these minimums on your mantel layout.
6. Standard sizes have been listed on the order forms. If you choose to vary from the standard sizes, please be aware that this will affect the dimensions for other areas as well. For example: When the depth of the mantel is reduced, the depth of the two side legs will also be reduced.
7. Double-check the wall sizes to the left and right of the mantel to ensure there is enough space available to accept the mantels and surrounds.
8. Please indicate on the order form if you would like your order unfinished or prefinished. You may select one of our standard stain colors, standard paint colors or a custom color match. *See page 56 for pricing on prefinishing.

Lead Times: Lead times will vary from week to week depending on our workload. Generally, your orders will ship as follows:

- Unfinished products - 10 business days
- Prefinished products - 15 business days

Packaging: Each mantel and surround will be packaged for shipment in four (4) pieces and must be fastened together at the job site. All pieces are packaged using heavy corrugated boxes lined with 1" styrofoam. Each piece is then placed in the box and surrounded with an expanding bagged foam material that will form to the shape of the contents and the box.

Packaging Charges will be added for each piece that is boxed and prepared for shipment by UPS or Common Carrier as follows:

- SXXX.XX per Mantel/Lower Surround
- SXX.XX per Upper Panel

*Add a SXX.XX Skid Charge for Common Carrier shipments.

*Note: You may deduct SXX.XX from the list price of the mantels for any order that is picked up at our plant and that does not require any packaging.

Shipping: Shipping charges are not included.

Mantel and Lower Surround – Unfinished

Width: 60" - 84"	Red Oak	Hard Maple	Cherry
Devonshire FP-700	X	X	X
Bradbury FP-710	X	X	X
Fairmont FP-715	X	X	X
Glenbrook FP-720	X	X	X
Edgewood FP-725	X	X	X
Chesapeake FP-740	X	X	X
Ashby FP-750	X	X	X

*Add 2% per Inch over 84" wide.
*Add shipping and packaging charges — see page 61.

Upper Panel – Unfinished (Up to 44" in Height)

Width: 60" - 84"	Red Oak	Hard Maple	Cherry
+Devonshire FP-600	X	X	X
Bradbury FP-610	X	X	X
Fairmont FP-615	X	X	X
Glenbrook FP-620	X	X	X
Edgewood FP-625	X	X	X
Chesapeake FP-640	X	X	X
Ashby FP-650	X	X	X

*Add 2% per Inch over 84" wide or 44" high.
*Add shipping and packaging charges — see page 61.
+Angled top-section is not included — call for price quote.

Prefinishing Mantels and Surrounds

Prefinished Charges for Upper Panels, Mantels and Surrounds will be priced by the square foot. Figure the total square footage as follows:

Mantel Shelf & 2 Legs: Multiply the total width by the total height (including 2 leg panels) and divide by 144. Multiply this number by the price per square foot found on page 34.

Upper Panel: Multiply the width by the height and divide by 144. Multiply this number by the price per square foot found on page 34.

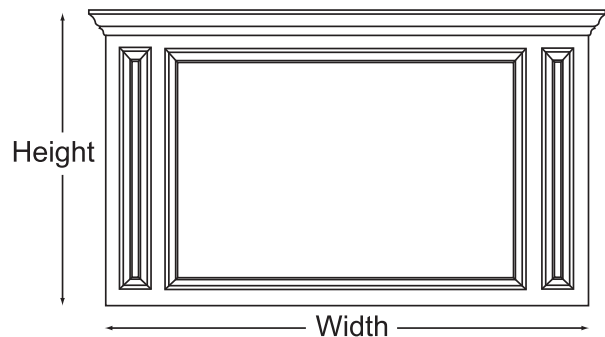
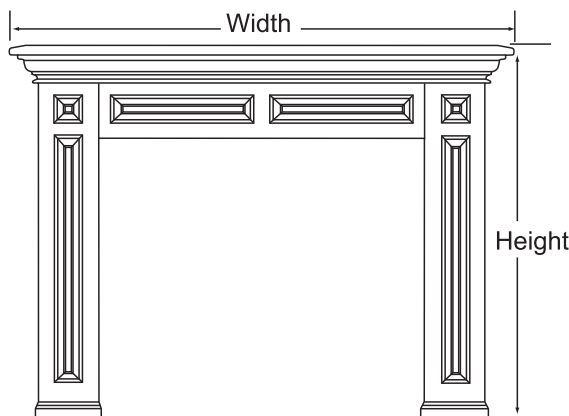



Valley Custom Door

A Division of Valley Cabinet, Inc.

Phone 1-800-236-8981

Fax 920-336-5956

Company Name: _____ Panel Profile: _____
 Job Name/P.O.#: _____
 Wood Type: _____ Stile & Rail: _____
 Prefinish Color: _____
 Notes: _____

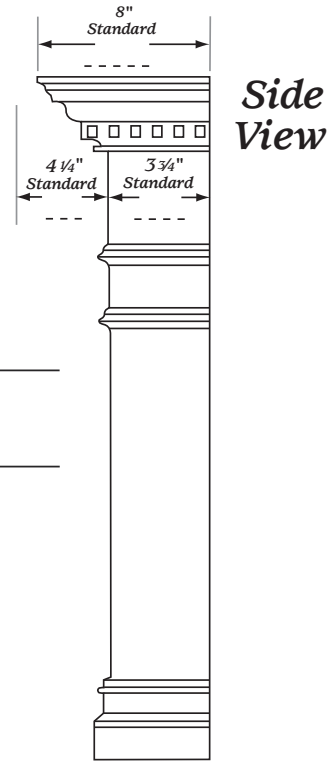

Top View of Leg

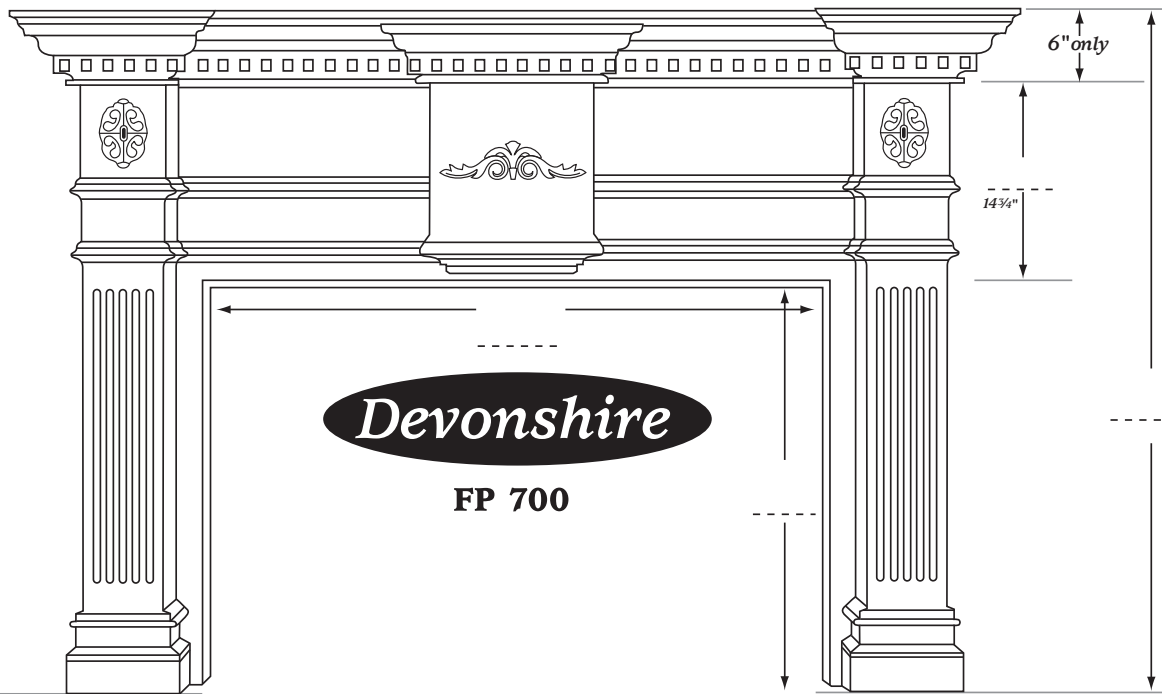
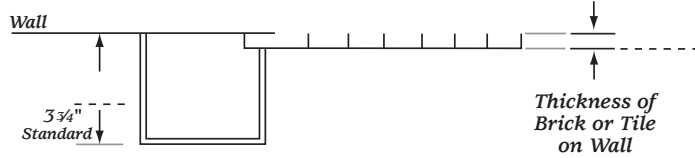

Devonshire

FP 700

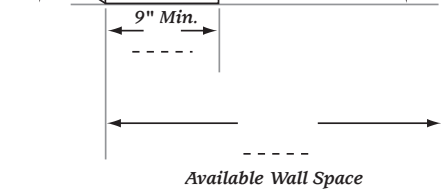
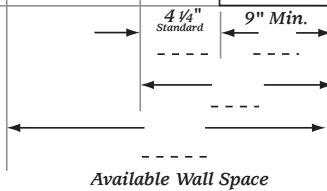

Devonshire

FP 600

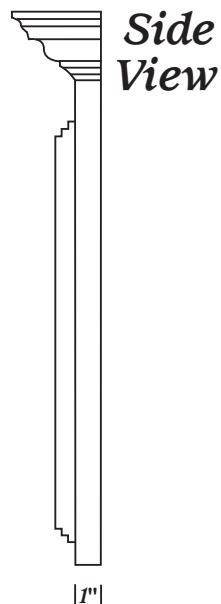
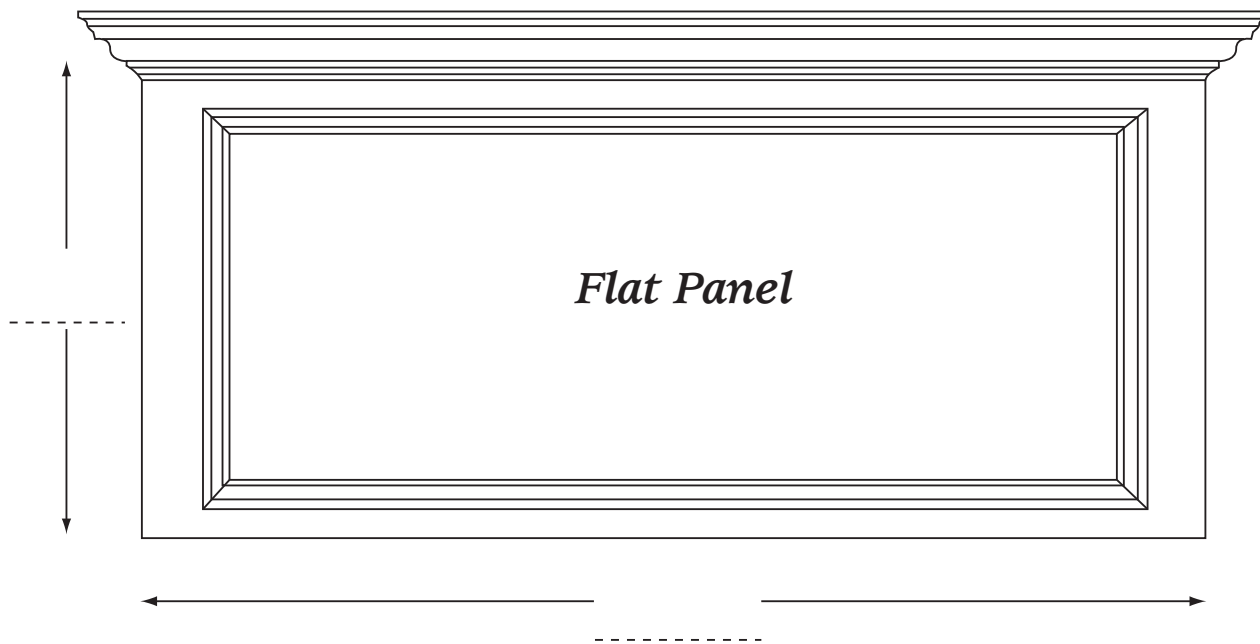

Phone 1-800-236-8981
Fax 920-336-5956

Company Name: _____
 Job Name/P.O.#: _____
 Wood Type: _____
 Prefinish Color: _____
 Notes: _____

Panel Profile: _____
 Stile & Rail: _____



Valley Custom Door

A Division of Valley Cabinet, Inc.

Phone 1-800-236-8981

Fax 920-336-5956

Company Name: _____

Panel Profile: _____

Job Name/P.O.#: _____

Wood Type: _____

Stile & Rail: _____

Prefinish Color: _____

Notes: _____

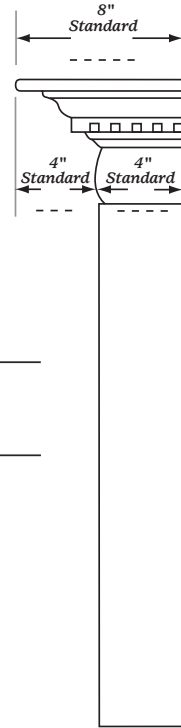

Side View

Top View of Leg

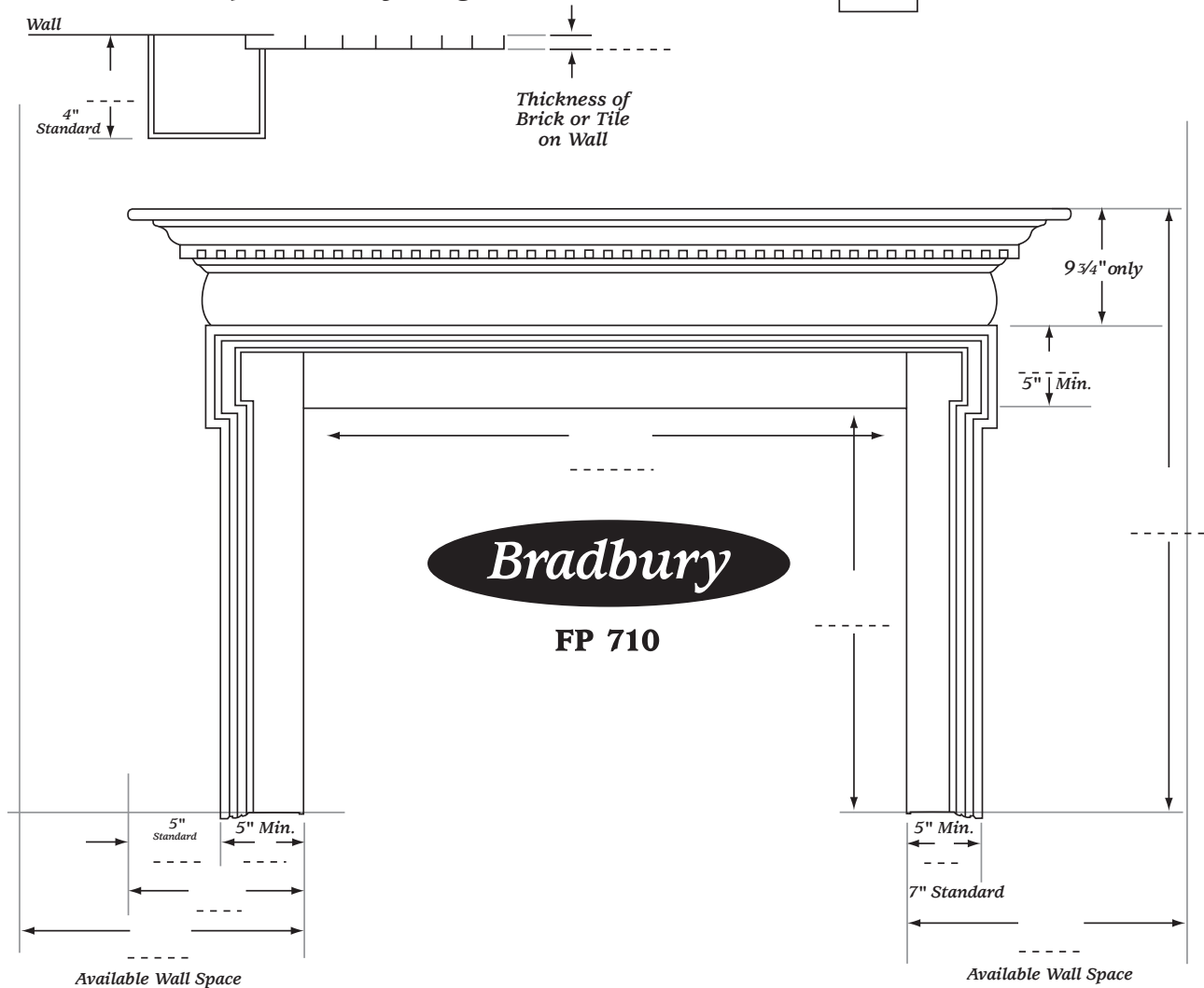

Bradbury

FP 610

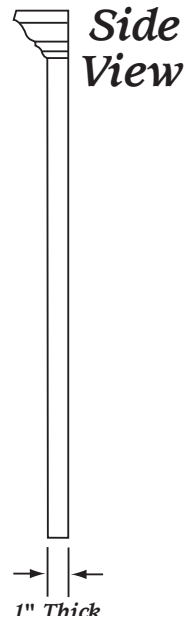
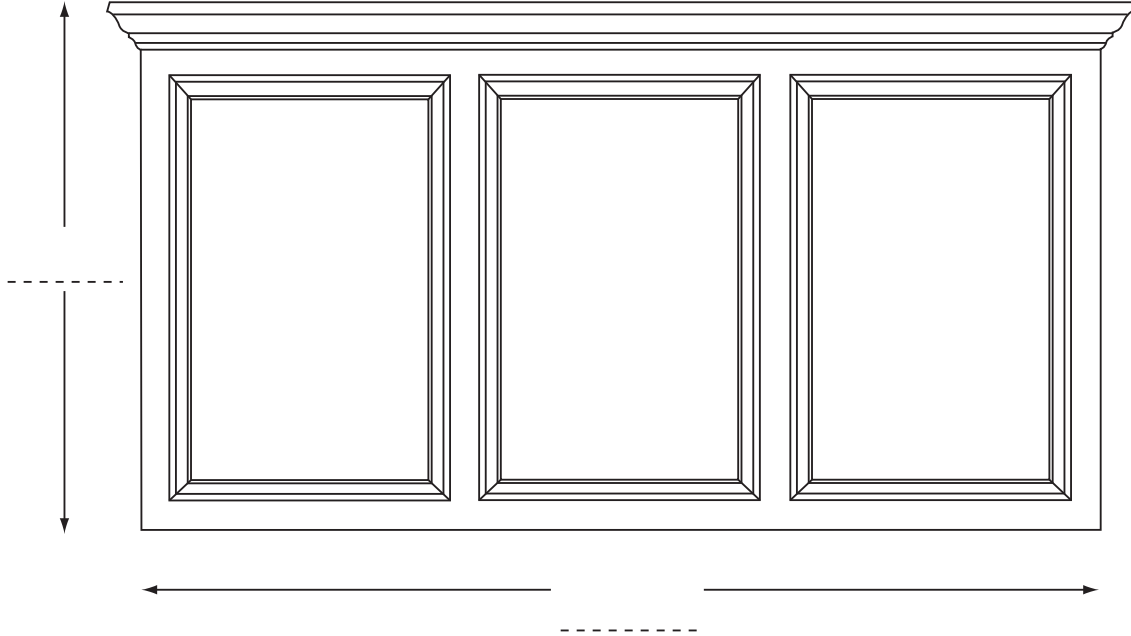

Valley Custom Door

A Division of Valley Cabinet, Inc.

Phone 1-800-236-8981

Fax 920-336-5956

Company Name: _____

Job Name/P.O.#: _____

Wood Type: _____

Prefinish Color: _____

Notes: _____

Panel Profile: _____

Stile & Rail: _____



Valley Custom Door

A Division of Valley Cabinet, Inc.

Phone 1-800-236-8981

Fax 920-336-5956

Company Name: _____ Panel Profile: _____
 Job Name/P.O.#: _____
 Wood Type: _____ Stile & Rail: _____
 Prefinish Color: _____
 Notes: _____

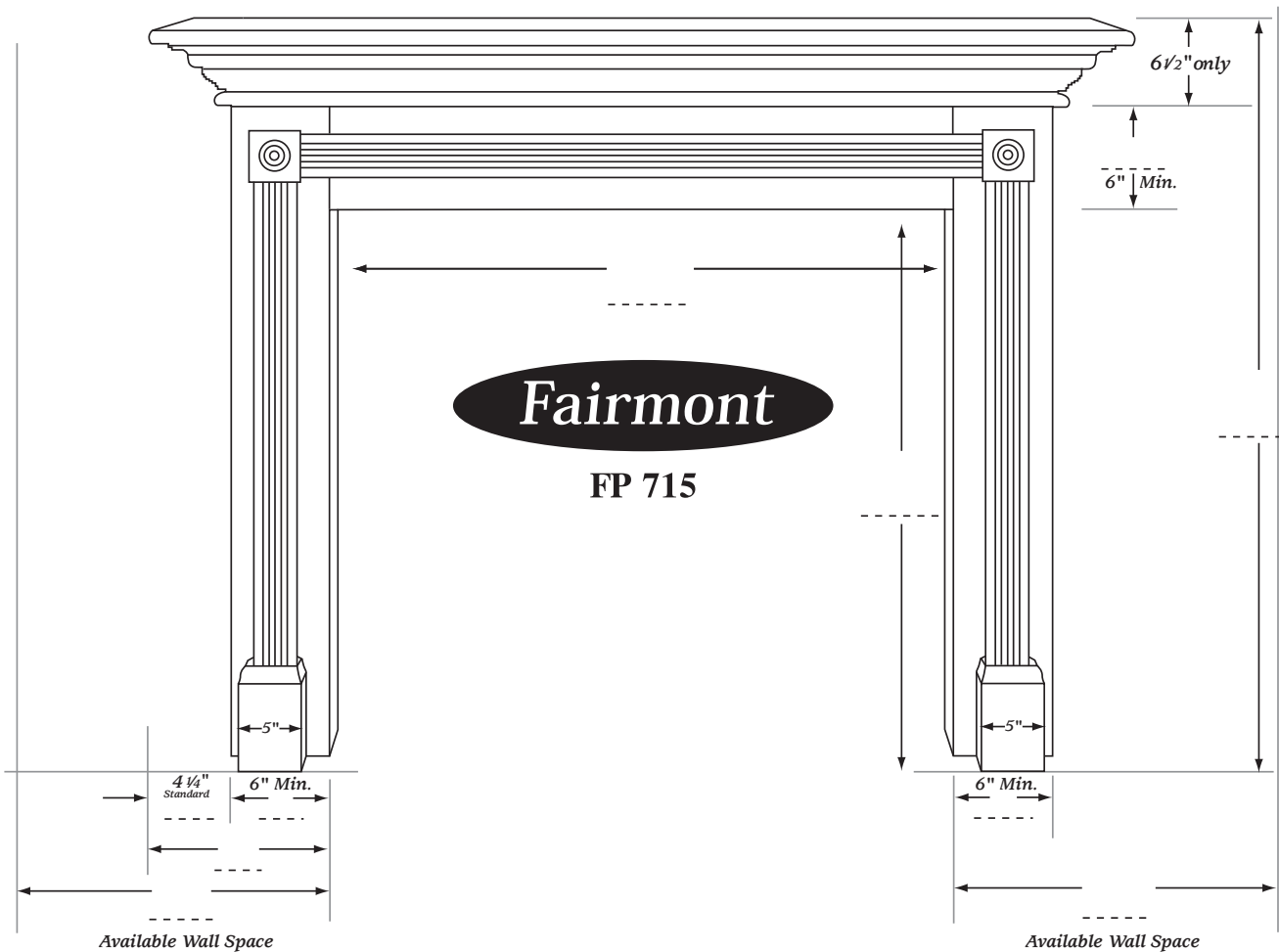
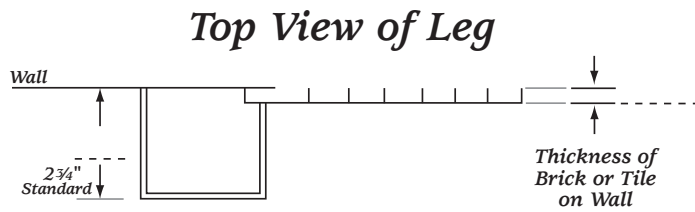
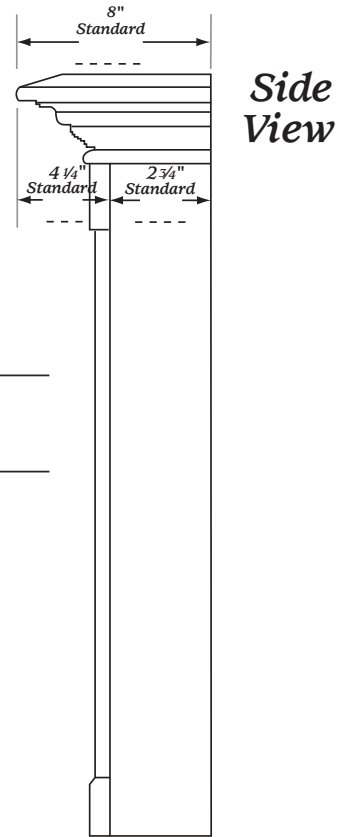

Fairmont

FP 615

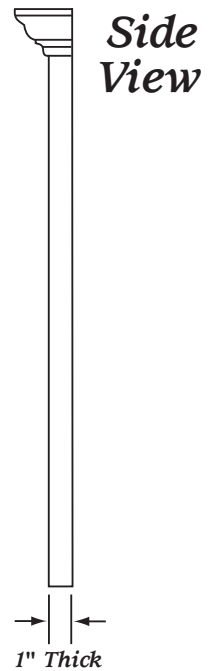
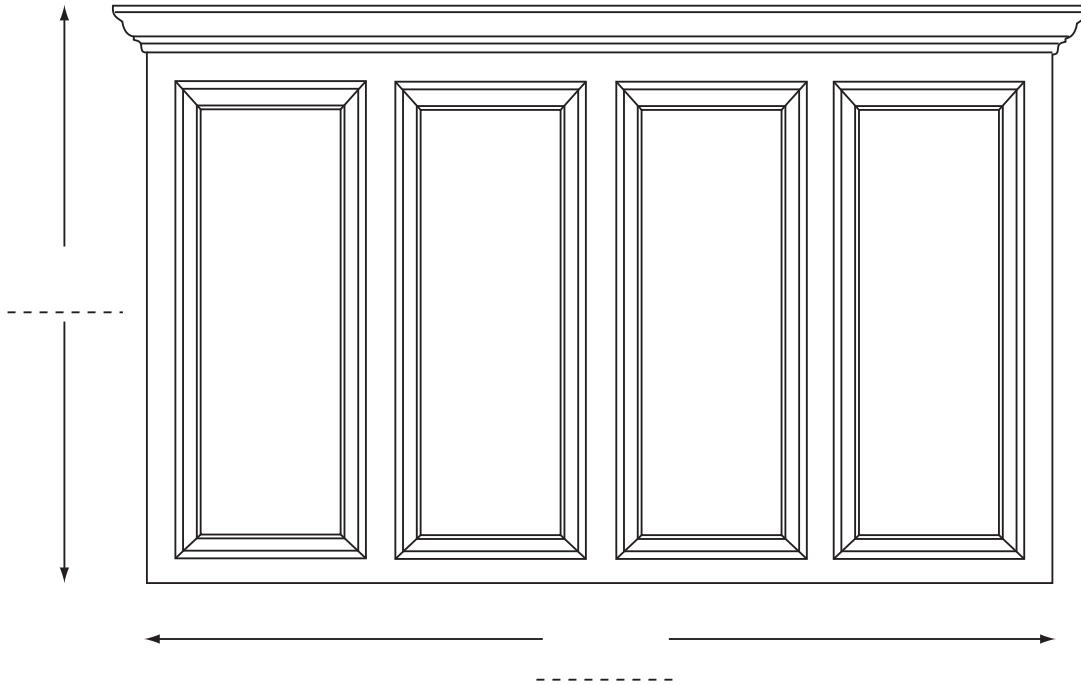

Valley Custom Door

A Division of Valley Cabinet, Inc.

Phone 1-800-236-8981

Fax 920-336-5956

Company Name: _____

Job Name/P.O.#: _____

Wood Type: _____

Prefinish Color: _____

Notes: _____

Panel Profile: _____

Stile & Rail: _____



Valley Custom Door

A Division of Valley Cabinet, Inc.

Phone 1-800-236-8981

Fax 920-336-5956

Company Name: _____ Panel Profile: _____
 Job Name/P.O.#: _____
 Wood Type: _____ Stile & Rail: _____
 Prefinish Color: _____
 Notes: _____

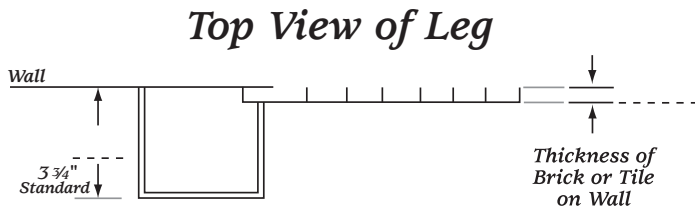
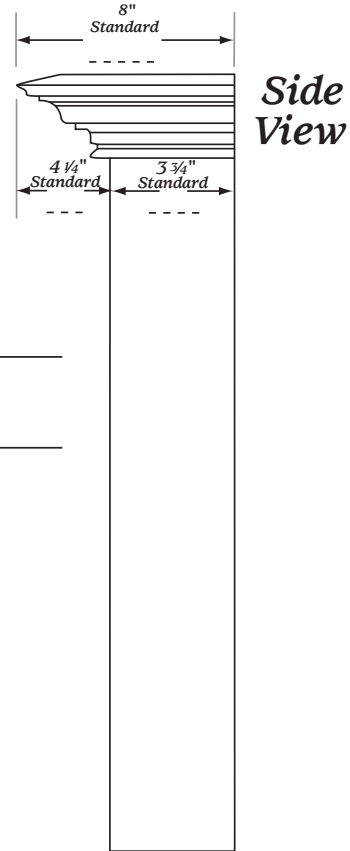

Available Wall Space

Available Wall Space

Glenbrook

FP 620

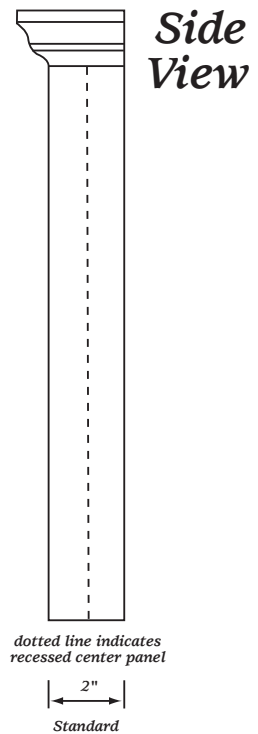
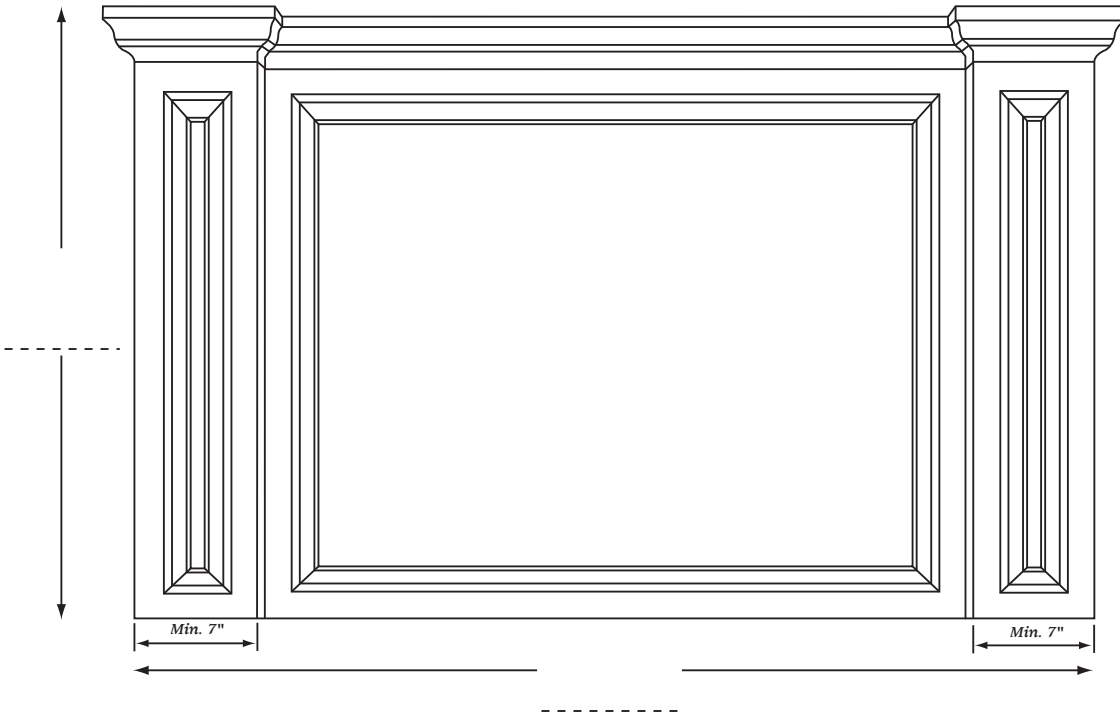

Valley Custom Door

A Division of Valley Cabinet, Inc.

Phone 1-800-236-8981

Fax 920-336-5956

Company Name: _____

Job Name/P.O.#: _____

Wood Type: _____

Prefinish Color: _____

Notes: _____

Panel Profile: _____

Stile & Rail: _____



Valley Custom Door

A Division of Valley Cabinet, Inc.

Phone 1-800-236-8981

Fax 920-336-5956

Company Name: _____

Panel Profile: _____

Job Name/P.O.#: _____

Wood Type: _____

Stile & Rail: _____

Prefinish Color: _____

Notes: _____

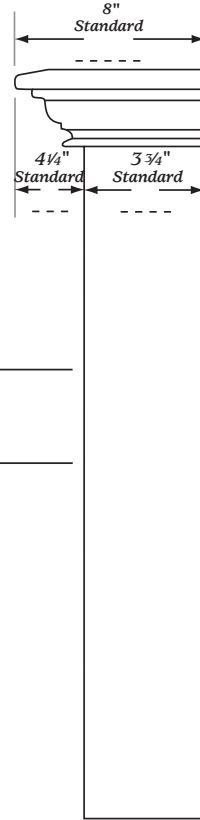

Side View

Top View of Leg

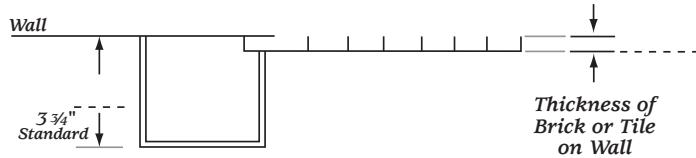

Edgewood
FP 725

Available Wall Space

Available Wall Space

Edgewood

FP 625

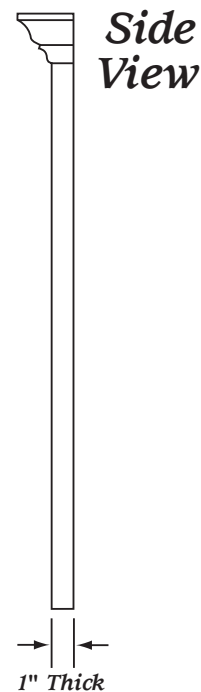
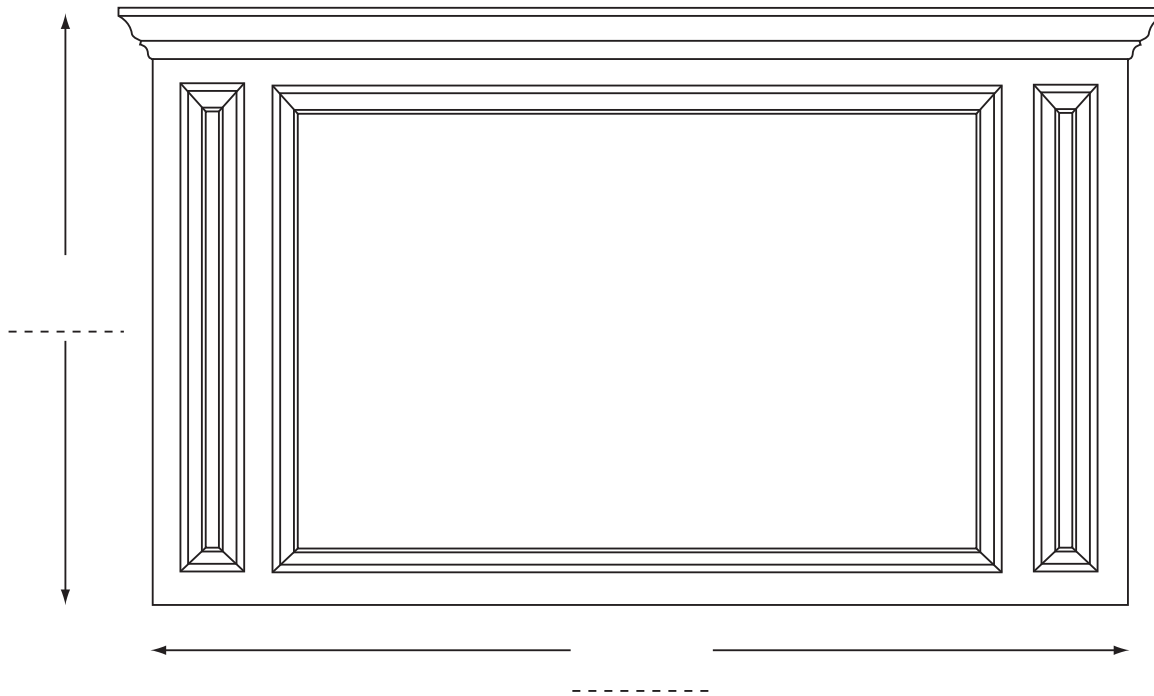

Valley Custom Door

A Division of Valley Cabinet, Inc.

Phone 1-800-236-8981

Fax 920-336-5956

Company Name: _____

Job Name/P.O.#: _____

Wood Type: _____

Prefinish Color: _____

Notes: _____

Panel Profile: _____

Stile & Rail: _____



Valley Custom Door

A Division of Valley Cabinet, Inc.

Phone 1-800-236-8981
Fax 920-336-5956

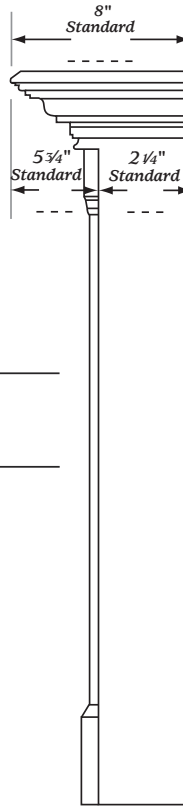

Side View

Company Name: _____ Panel Profile: _____
 Job Name/P.O.#: _____
 Wood Type: _____ Stile & Rail: _____
 Prefinish Color: _____
 Notes: _____

Top View of Leg

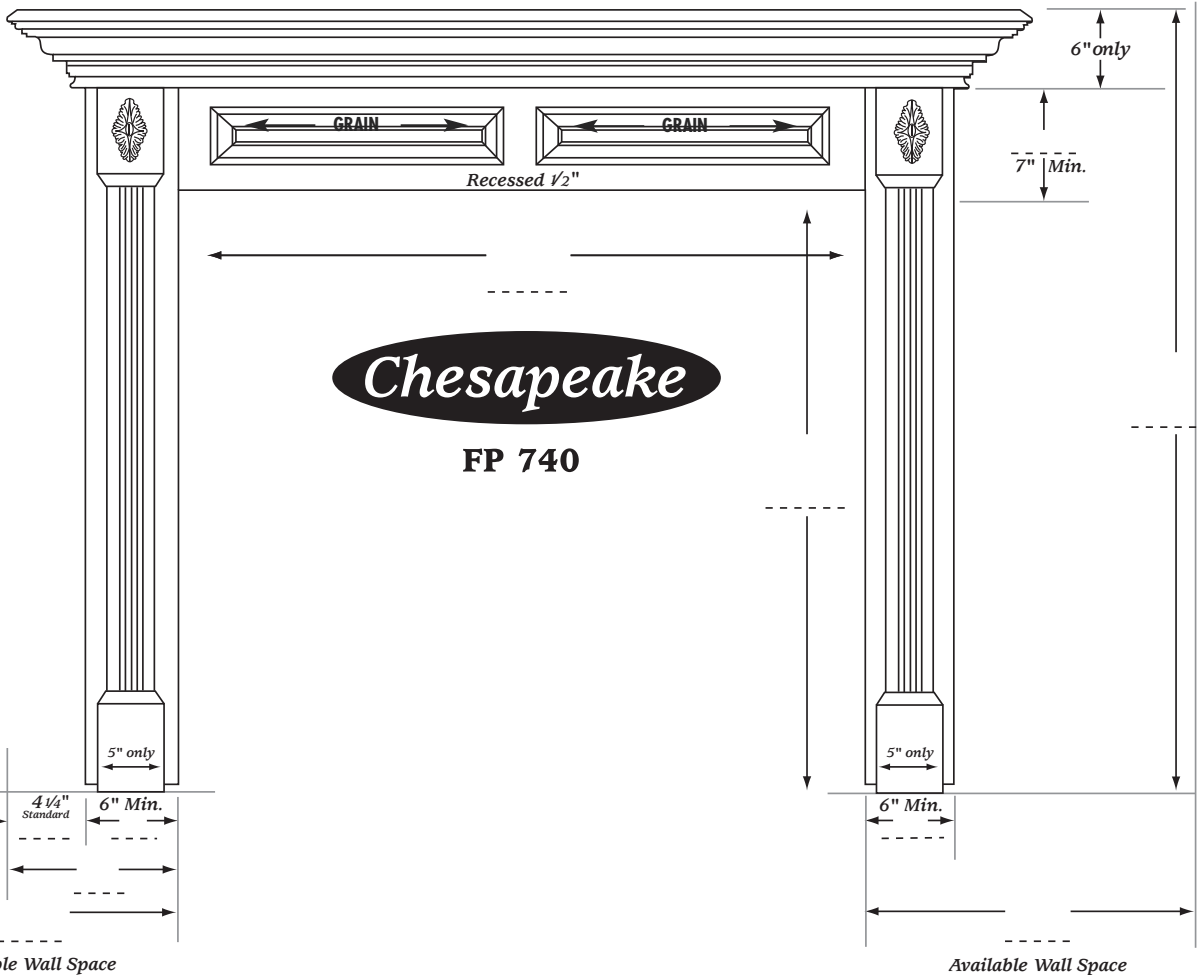
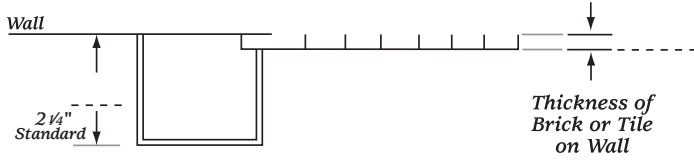

Chesapeake

FP 640

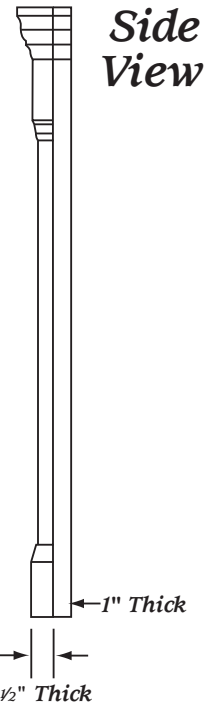
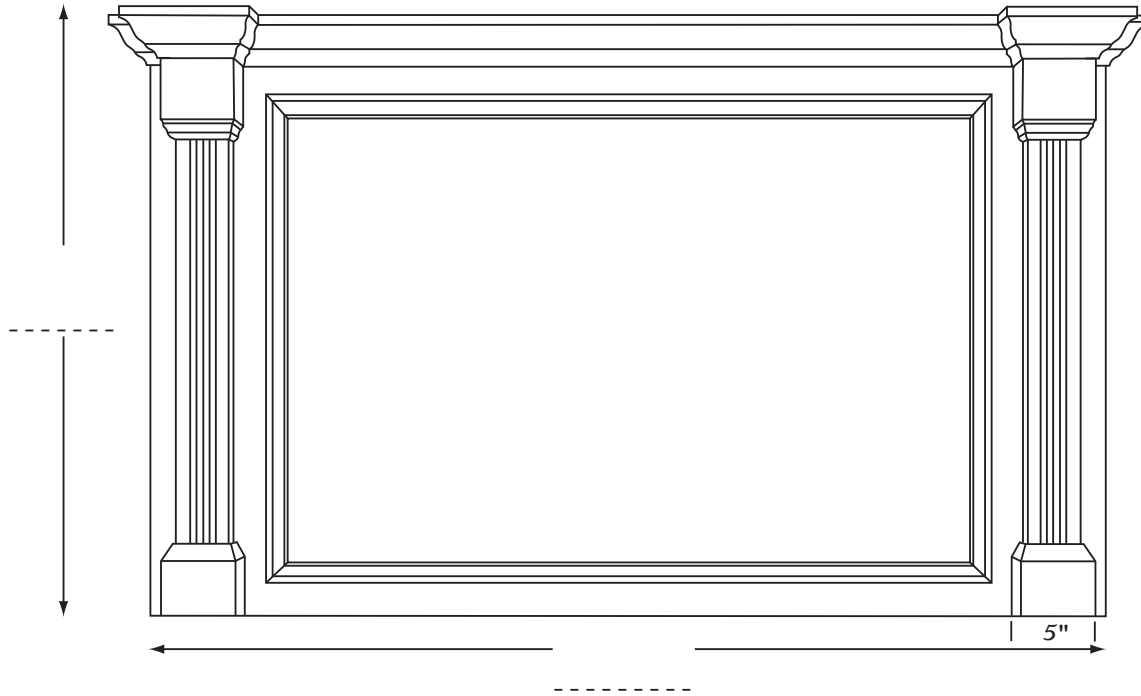

Phone 1-800-236-8981
Fax 920-336-5956

Company Name: _____
 Job Name/P.O.#: _____
 Wood Type: _____
 Prefinish Color: _____
 Notes: _____

Panel Profile: _____
 Stile & Rail: _____



Valley Custom Door

A Division of Valley Cabinet, Inc.

Phone 1-800-236-8981

Fax 920-336-5956

Company Name: _____

Panel Profile: _____

Job Name/P.O.#: _____

Wood Type: _____

Stile & Rail: _____

Prefinish Color: _____

Notes: _____

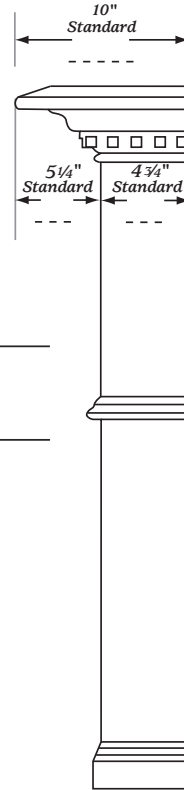

Side View

Top View of Leg

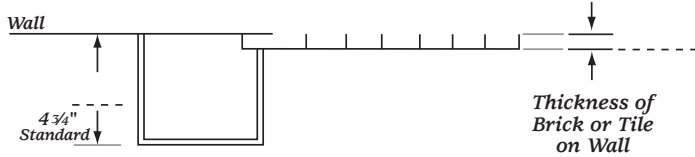

Ashby

FP 750

Ashby

FP 650

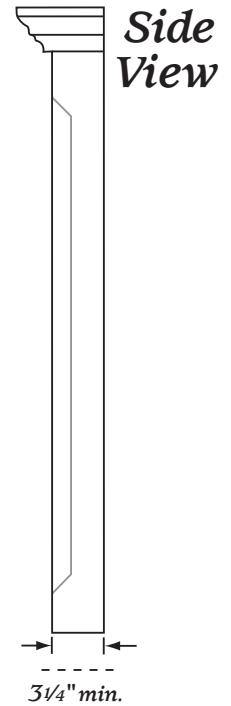
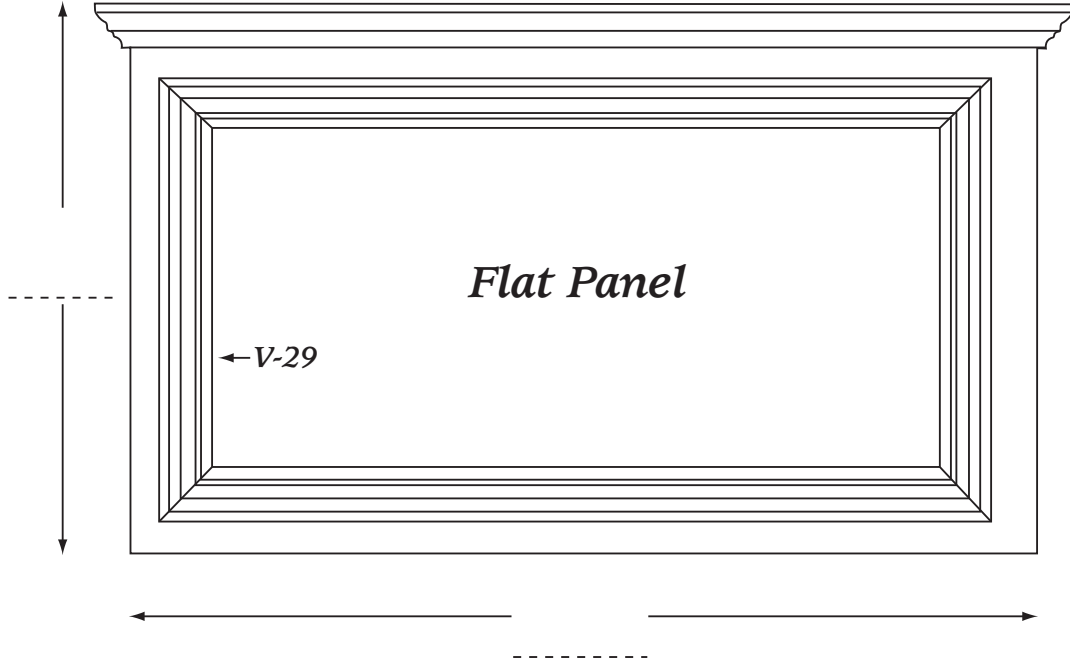

A Division of Valley Cabinet, Inc.

Phone 1-800-236-8981

Fax 920-336-5956

Company Name: _____

Job Name/P.O.#: _____

Wood Type: _____

Prefinish Color: _____

Notes: _____

Panel Profile: _____

Stile & Rail: _____

1/4" Flat Veneer MDF Core Panels	8	Glass Doors, Pricing	19	Profiles, Mitred Doors & Drawer Fronts	20-22
1/4" Panel Doors, Pricing	17-18	Glaze	35	Profiles, Doors, Outside Edges	10
1/4" S4S Face Frame Stock Finished, Unfinished	62	Glazing Pricing	36	Profiles, Panels	8
3/4" S4S Face Frame Stock Finished, Unfinished	61	Glenbrook	73-74	Profiles, Stiles & Rail	9
3/4" Slab Style Drawer Fronts, Pricing	11	Grain Direction Panels	13	Profiles, MDF Veneer Doors	34
3/4" and 1" Slab Style Drawer Fronts, Pricing	12	H		Pull-Out Fronts	39
5-Piece Cope & Stick Style Door Fronts Only	13	Half Lap Edges, Specifications & Pricing	41	Pull-Out Waste Containers	42
5-Piece Door Fronts	14	HB-1	39	Q	
A		Heirloom Finish	35	Quarter Circle Doors, Pricing & Specifications	29
Appliance Garage	50	Hinge Boring Charts, Concealed, Pricing & Specifications	45-46	R	
Appliance Panels, Specifications, Pricing	44	How To Use This Specification Guide	3-5	Radius Corners, Specifications & Pricing	41
Applied Moulding Doors & Drawers, Profiles, Pricing	25-27	I, J, K, L		Raised Panel Doors, Pricing	14-15
Ashby Mantle & Surrounds, Specifications, Pricing	79-80	Index	81	Raised Panel Profiles	8
B		Integral Fluted Rails w/Rosette	55	Rosettes	56
Beaded Face Frame Pricing Unfinished	54	Knife Block Insert	39	Routed Finger Pulls	41
Blower Units	49	Lazy Susan Doors-Corner Doors, Trays Pricing & Specifications	42	Rush Orders-Upcharge	3
Bradbury Mantle & Surrounds, Specifications, Pricing	69-70	Lazy Susans By Rev-A Shelf®	42	Rustic Grade Wood	5
Bread Boards - Veneer, Pricing & Specifications	41	Liner, Hood	49	S	
Butt Edge Doors, Specifications & Pricing	42	Louvered Doors	16	Sales Kit, Sales Kit Case	6
C		M		Samples, Doors, Policy	35
Chesapeake Mantle & Surrounds, Specifications, Pricing	77-78	Mantel Shelf	51	Scoop Front	39
Color Door Display	6	Mantel & Surrounds	64-80	Shelves, Specifications & Pricing	43
Color Samples, Color Sample Box, Chain Set, Case	6	Mantel & Surrounds Ordering Information	65	Shipping	3
Color Sample Chain Set	35	Mantel & Surrounds Pricing	66	Slab Doors & Drawer Profiles 3/4"	11
Color Sample Display Board	6	Mantel & Surrounds Styles & Order Forms	67-80	Slab Door & Drawer Fronts 3/4" and 1"	12
Complete Color Sample Box	35	MDF Flat Veneer Core Panel	8	Slab Panel Door Pricing	30
Concealed Hinges, Boring Chart, Pattern	46	MDF One-Piece Glass w/Mullions, Specifications, Pricing	33	Sliding Drawer Within A Drawer	40
Corner Doors-Lazy Susan Doors, Pricing & Specifications	38	MDF One-Piece Glass Raised Panel Doors, Spec, Pricing	34	Solid Wood Door Specifications, Pricing	30
Corner Drawer	38	MDF Veneer Doors, Profiles, Pricing	31	Solid Wood Cabinet Face Frame	53-54
Custom Color Matches	35	Millwork	55-60	Solid Face Frame Stock 1/4"	62
Custom Wainscot Panels, Pricing	32	Minimum Size Requirement	4	Solid Face Frame Stock 3/4"	61
Custom Wood Hoods	47-48	Mitred Door & Drawer Profiles, Fronts, Pricing	21-24	Spice Tray	39
Customized Finishes	35	Mouldings & Millwork, Sketches	57-58	Stain Colors Standard	35
D		Mouldings, Pricing, Finished, Unfinished	59-60	Stain & Glaze Combinations	35
Damage	3	Mullion Profiles	9	Stain For Purchase	35
Devonshire Mantle & Surrounds, Specifications, Pricing	67-68	N		Standard Grade Wood	5
Display Products & Sample	6	New Customer/First Order	3	Steps To Follow When Ordering Door & Drawer Fronts	4
Distressed Finishes	35	Notching For Undermount Drawer Track	38	Stile & Rail Profiles	9
Door And 5-Piece Door Front Outside Edge Profiles	10	Notes	28, 52	Stile & Rail Profiles/Frame Only Doors	9
Door Construction	7	O		T	
Door Profiles	10	One-Piece MDF-Glass Doors w/Mullions, Pricing	33	Table of Contents	2
Drawer Dividers	40	One-Piece MDF-Raised Panel Doors, Profiles, Pricing	34	Top Mount Pull-Out Waste Containers By Rev-A Shelf	42
Drawer Front 5-Piece	10	One-Piece MDF, Drawer Profiles, Outside Edges, Stile & Rails	34	Typical Mitred Construction	7
Drawer Peg System	39	Options	41-42	U, V	
Drawer Within A Drawer	40	Ordering Doors & Drawers	4	Valances, Pricing & Specifications	43
Dovetailed Drawer Boxes, Assembly Options, Pricing	37-40	Ordering, Procedure	4	Value Grade	5
E		Outside Edge Profiles For Doors	8-10	Veneer Bread Board	41
Edges Available - Doors	10	P		Veneer & Plywood Panels Finished, Unfinished	63
Edges Available - Drawer Fronts	11-12	Painting Colors Standard	35	Vintage Finish	35
Edge Profiles, Doors	10	Paint & Color Combination	35	V-Groove Panel Pricing	8
Edgewood Mantle & Surrounds, Specifications, Pricing	75-76	Paint For Purchase	35	W	
F		Paint Grade Wood	5	Wainscot Panels, Pricing & Specifications	32
Face Frames, Assembled	53-54	Panel Profiles	8	Wine Rack Lattice, Prefinished, Unfinished	41
Face Frame Plain, Prefinished, Unfinished	53	Payment Terms/Terms	3	Warranty & Remake Policy	3
Face Frame Beaded, Prefinished, Unfinished	54	Peg System	39	Waste Containers, Top Mount Pull-Out Rev-A-Shelf®	42
Fairmont Mantle & Surrounds, Specifications, Pricing	71-72	Plain Face Frame Pricing Unfinished	53	Wire Mesh Grills	19
Finger Pulls, Specifications & Pricing	41	Plinths	56	Wood, Species Guide	5
Flow Pen	35	Plywood and Veneer Panels Unfinished, Prefinished	63	Wood Hoods, Custom	47-48
Fluted Rails, w/Integral Rosette, Pricing & Specifications	55-56	Prefinishing	35	Wood Hood Blower	49
Framed Glass Doors, Pricing	19	Prefinishing Pricing	36	Wood Hood Liner	49
Framed Glass Doors w/Mullions, Pricing	20	Premium Grade Wood	5	Wood Knife Block Insert	39
Freight Damage	3	Pricing	3		
G		Price Quotations	3		
Glass Doors Framed, Specifications, Pricing	19	Product Samples	6		
Glass MDF Doors w/Mullions	33	Profiles, Applied Moulding	26		
Glass Doors w/Mullions	19	Profiles, Drawer Fronts	10		
		Profiles, 5-Piece Drawer Fronts	13		